

Single Family Residential One Story Detached Garage

Note: For roofs with slopes less than 4:12, follow manufacturer's instructions for low slope application of roofing material.

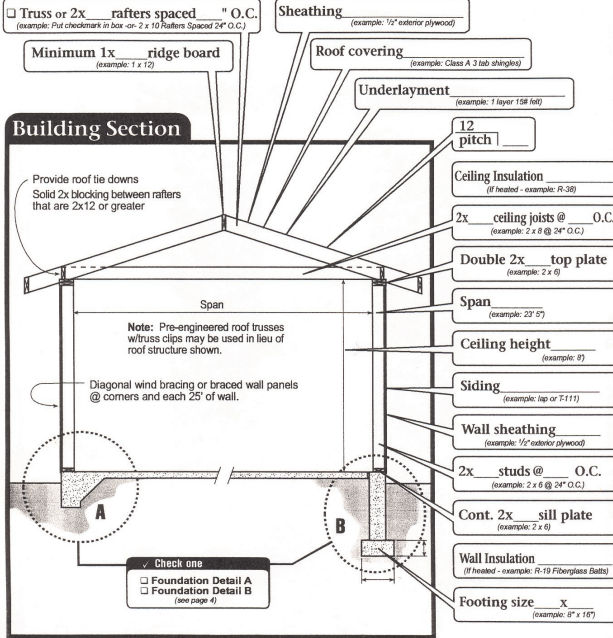

Diagram A

These drawings are samples only and will not be acceptable as the only construction documents.

Design Criteria

Ground Snow load	31 lb/sqft
Wind load	115 mph (exposure C)
Seismic	D1
Frost Depth	30 inches

All plans and inspections are based off the International Residential Code as currently adopted by the State of

Single Family Residential One Story Detached Garage

Foundation Detail A

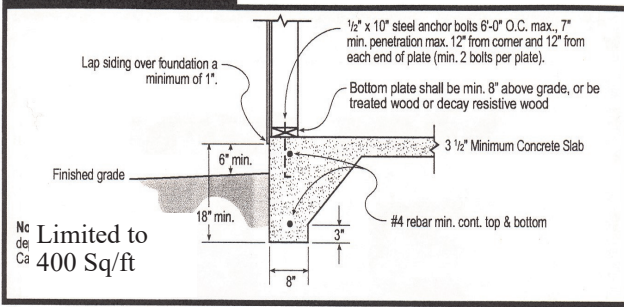

Foundation Detail B

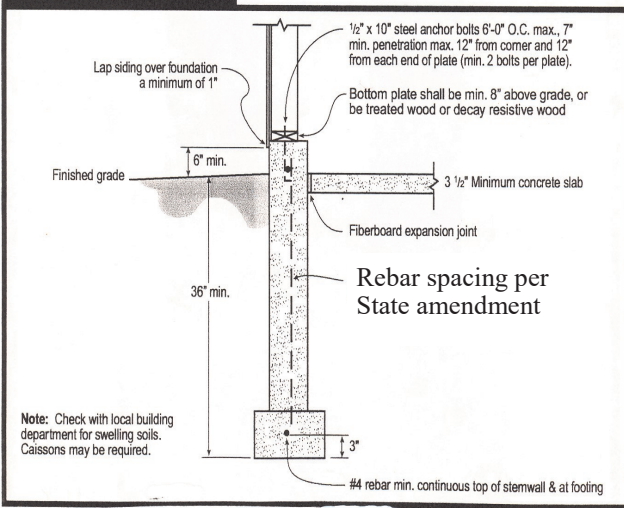

Accessory Building Construction

Community Development Building Division



Building Requirements

Any detached accessory structure that has one or more of the following requires a permit; 200 sq/ft or more, multilevel, has electrical, plumbing, heating, or cooling. Structures smaller than 200 sq/ft do not require permits but still require the setbacks found in the Springville City Development Code.

Requirements for Submitting a Permit Application for an accessory structure:

1. Permit submissions must be completed at <https://www.springville.org/community-development/building-division/> in My City Inspector. Plans are uploaded on the website.
2. Plan check fees are due at time of plan submission and can be paid in the office with CASH or CHECK only, or an echeck by phone.
3. Electronic copies of site plan, construction drawings, elevations and engineering if needed.
 - a. Truss information .
 - b. Include electrical plumbing and mechanical information as needed.

110 S. Main Street
Springville, UT 84663
801.489.2704

<https://www.springville.org/community-development/building-division/>
buildingpermits@springville.org

- c. Footing information- (see foundation detail samples A and B)
- d. Framing plan including information found on diagram A to meet the listed design criteria.
- e. Fire resistive construction for walls if needed for set back proximity.

Submit application and plans at <https://www.springville.org/community-development/building-division/>

Plan review will take approximately 2-3 weeks. It may take longer if we call for corrections to be made to the plans. When plans have been approved, stamped and fees calculated, we will contact you with the permit amount. Payment can be made with CASH or CHECK only or an echeck payment by phone. After the permit has been paid for, work may commence.

Inspections required:

- Footing inspection when excavated and formed with reinforcement secured, but before concrete is poured.
- Foundation inspection when forms are in place and steel tied, ready to place concrete.
- Rough building inspection prior to covering exterior or installation of insulation.
- Final inspection when the structure is complete prior to occupancy

Inspections can be scheduled on My City Inspector or by calling the Building Department at 801.489.2704 at least one business day before you wish to schedule each inspection. An adult must be present to meet the inspector at the property. After all inspections have been successfully completed, keep the plans, permit and inspection reports with your house records. For any questions or comments please contact the building department at 801.489.2704 / buildingpermits@springville.org.

Permits only expire if work is vacated for a period greater than 180 days.

TYPICAL SITE PLAN

CHECK LIST

1. Show dimensions of the property.
2. Put address of home on the street the house faces.
3. Show names of bordering streets, if on a corner.
4. Show location and dimensions of existing and proposed buildings, structures and parking areas.
5. Identify the use of all existing and proposed structures including the number of stories.
6. Show distance between buildings (minimum 6'), and distances from buildings and structures to property lines (minimum 3').
7. Show any retaining walls using small circles. **All walls must be built inside of your property lines.** (No alteration to the land of any kind can obstruct or alter the path of flow of any drainage easement used in the design of the subdivision to drain your lot and neighboring lots. Any change in drainage design must have an alternate method of maintaining the flow approved by the City prior to changes being made.)
8. Show height, length and type of any retaining wall(s).
9. Include north arrow.
10. Show and identify any easements.
11. Show all architectural projections including stairs, balconies, porch covers, decks, etc.
12. Show drainage using arrows.
13. If a structure is closer than 5 feet to the property line, then fire-resistive construction is required. Show a notation on the site plan and details on the construction drawings.

