



Appendix B

BMP SPECIFICATION SHEETS



APPLICATIONS

- Manufacturing
- Material Handling
- Vehicle Maintenance
- Construction
- Commercial Activities
- Roadways
- Waste Containment
- Housekeeping Practices



DESCRIPTION:

Area control procedures involve practicing good housekeeping measures such as maintaining indoor or covered material storage and industrial processing areas. If the area is kept clean, the risk of accumulating materials on footwear and clothing is reduced. In turn, the chance of left over pollutants making contact with stormwater polluting surface water is minimized.

APPROACH:

Area control procedures can be used at any facility where materials may be tracked into areas where they can come in contact with stormwater runoff. Areas can include material handling areas, storage areas, or process areas.

Effective practices include the following:

- Cover garments, foot mats, and other devices used to collect residual material near the area should be cleaned regularly.
- Brush off clothing before leaving the area.
- Stomp feet to remove material before leaving the area.
- Use floor mats at area exits.
- Use coveralls, smocks, and other overgarments in areas where exposure to material is of greatest concern (employees should remove the overgarments before leaving the area).
- Post signs to remind employees about these practices.

LIMITATIONS:

May be seen as tedious by employees and therefore may not be followed.

MAINTENANCE:

Materials storage areas and industrial processing areas should be checked regularly to ensure that good housekeeping measures are implemented.

TARGETED POLLUTANTS

- High Impact
 - Medium Impact
 - Low or Unknown Impact

- Sediment
- Heavy Metals
- Toxic Materials
- Oxygen Demanding Substances
- Oil & Grease
- Floatable Materials
- Bacteria & Viruses

IMPLEMENTATION REQUIREMENTS

- Capital Costs
- O&M Costs
- Maintenance
- Training

- High
- Medium
- Low

Materials Adopted From Salt Lake County Engineering Division Guidance Document

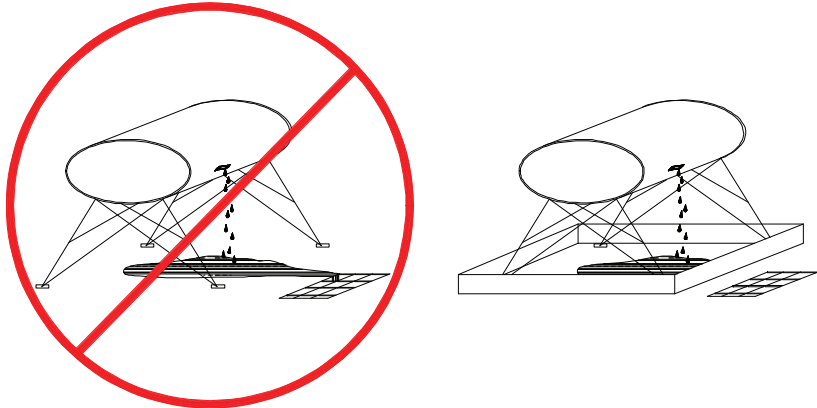

APPLICATIONS

- Manufacturing
- Material Handling
- Vehicle Maintenance
- Construction
- Commercial Activities
- Roadways
- Waste Containment
- Housekeeping Practices



DESCRIPTION:

Prevent or reduce the discharge of pollutants to stormwater from aboveground storage tanks by installing safeguards against accidental releases, installing secondary containment, conducting regular inspections, and training employees in standard operating procedures and spill cleanup techniques.

The most common causes of unintentional releases are:

- Installation problems,
- Failure of piping systems (pipes, pumps, couplings, hoses, and valves),
- External corrosion and structural failure,
- Spills and overfills due to operator error, and
- Leaks during pumping of liquids or gases from truck to a storage tank or vice versa.

APPROACH:

- Integrate efforts with existing aboveground petroleum storage tank programs through the local Fire Department and Health Department, and area and business emergency response plans through the City, County, or Fire District.
- Use engineering safeguards to reduce the chance for spills.
- Perform regular maintenance.

LIMITATIONS:

For larger spills, a private spill clean-up company or Hazmat team may be necessary.

MAINTENANCE:

Maintenance is critical to preventing leaks and spills. Conduct routine weekly inspections and:

- Check for external corrosion and structural failure,
- Check for spills and overfills due to operator error,
- Check for failure of piping system (pipes, pumps, flanger, coupling, hoses, and valves),
- Check for leaks or spills during pumping of liquids or gases from truck to storage facility or vice versa.
- Periodically, integrity testing should be conducted by a qualified professional.

TARGETED POLLUTANTS

- High Impact
- Medium Impact
- Low or Unknown Impact
- Sediment
- Nutrients
- Heavy Metals
- Toxic Materials
- Oxygen Demanding Substances
- Oil & Grease
- Floatable Materials
- Bacteria & Viruses

IMPLEMENTATION REQUIREMENTS

- Capital Costs
 - O&M Costs
 - Maintenance
 - Training
- High • Medium • Low

Materials Adopted From Salt Lake County Engineering Division Guidance Document

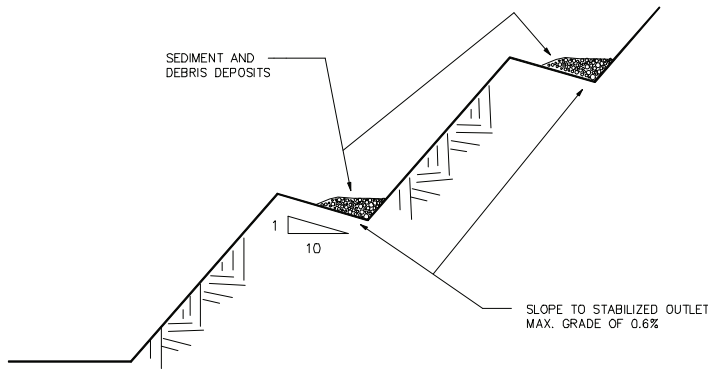

OBJECTIVES

- Housekeeping Practices
- Contain Waste
- Minimize Disturbed Areas
- Stabilize Disturbed Areas
- Protect Slopes/Channels
- Control Site Perimeter
- Control Internal Erosion



DESCRIPTION:

Slope construction with benches spaced at regular intervals perpendicular to the slope which intercept and collect sheet flow and direct it to a stable outfall point.

APPLICATION:

- Unstabilized cut and fill slopes
- Large stockpiles
- Existing unstable slopes

INSTALLATION/APPLICATION CRITERIA:

- Benches should be formed as slope is constructed and graded to the outlet point.
- Stabilized outlet with sediment controls should be in place prior to slope construction.

LIMITATIONS:

- Construction slope design must accommodate benching
- Not appropriate for sandy or rocky soil
- Only effective if suitable outlet provided

MAINTENANCE:

- Inspect after major storm events and at least biannually, repair any damaged areas
- Remove debris blocking water flow
- Inspect outlet, repair/replace sediment controls and remove sediment build up.

TARGETED POLLUTANTS

- High Impact
- Medium Impact
- Low or Unknown Impact

- Sediment
- Nutrients
- Toxic Materials
- Oil & Grease
- Floatable Materials
- Other Waste

IMPLEMENTATION REQUIREMENTS

- Capital Costs
- O&M Costs
- Maintenance
- Training

- High
- Medium
- Low

MATERIALS ADAPTED FROM SALT LAKE COUNTY ENGINEERING DIVISION GUIDANCE DOCUMENT

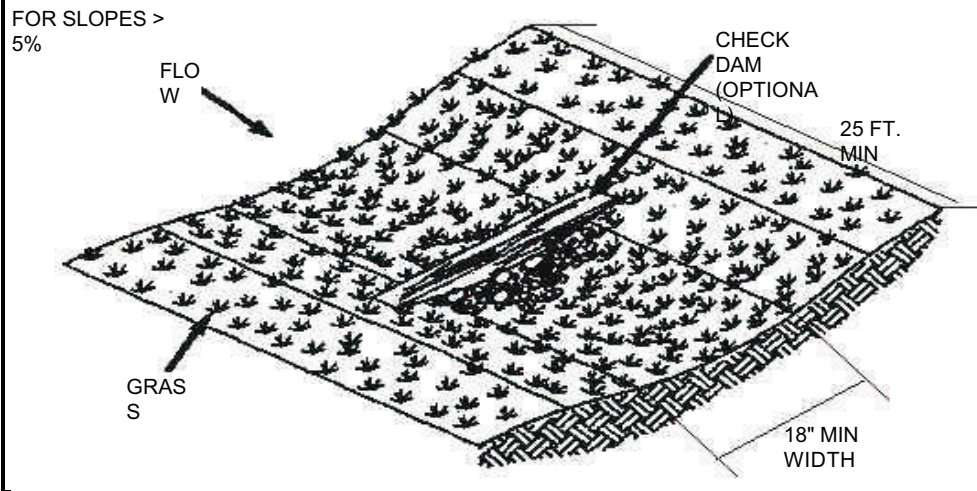

DESCRIPTION:

Biofilters are of two types: swale and strip. A swale is a vegetated channel that treats concentrated flow. A strip treats sheet flow and is placed parallel to the contributing surface.

APPLICATION:

Suitable for small catchment areas of a few acres.

INSTALLATION/APPLICATION CRITERIA:

- Comparable performance to wet ponds and constructed wetlands.
- Limited to treating a few acres and availability of water during dry season.
- The surface area must be defined.
- The minimum width for a swale is determined by Manning's Equation.
- Minimum length of a strip is 10 feet.
- The longitudinal slope must not exceed 5%.
- Use a flow spreader and energy dissipator at the entrance of a swale.
- Good soils are important to achieve good vegetation cover.

LIMITATIONS:

- Poor performance has occurred but this appears to be due to poor design.
- May be limited to areas where summer irrigation is feasible.
- Can be difficult to maintain sheet flow in strips.
- Can be difficult to avoid channelization in swales.
- Cannot be placed on steep slope.
- Area required may make infeasible on industrial sites.
- Proper maintenance required to maintain health and density of vegetation.

MAINTENANCE:

- Make sure soils are suitable for healthy vegetation.
- Level cross-section and even longitudinal slope for swales.
- Achieve sheet flow with strips.

CONSIDERATIONS

- Soils
- Area Required
- Slope
- Water Availability
- Aesthetics
- Hydraulic Head
- Environmental Side Effects



TARGETED POLLUTANTS

- High Impact
 - Medium Impact
 - Low or Unknown Impact

- Sediment
- Nutrients
- Heavy Metals
- Toxic Materials
- Oxygen Demanding Substances
- Oil & Grease
- Floatable Materials
- Bacteria & Viruses

IMPLEMENTATION REQUIREMENTS

- Capital Costs
- O&M Costs
- Maintenance
- Training

- High • Medium • Low

Materials Adopted From Salt Lake County Engineering Division Guidance Document

Fiber Roll

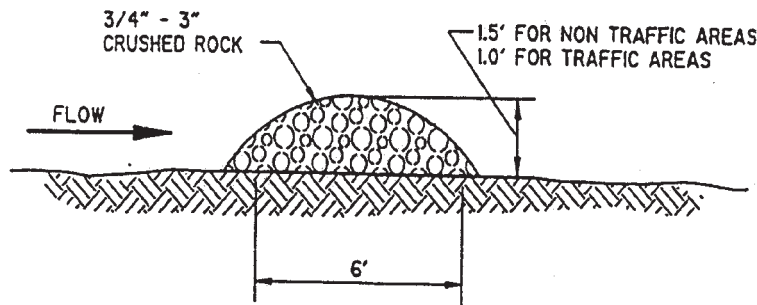

OBJECTIVES

- Housekeeping Practices
- Contain Waste
- Minimize Disturbed Areas
- Stabilize Disturbed Areas
- Protect Slopes/Channels
- Control Site Perimeter
- Control Internal Erosion



DESCRIPTION:

A rock filter is made of rock 3/4 - 3" in diameter and placed along a level contour. A brush filter is composed of brush (usually obtained during the site clearing) wrapped in filter cloth and anchored to the toe of the slope. If properly anchored brush or rock filters may be used for sediment trapping and velocity reduction.

APPLICATION:

- As check dams across mildly sloped construction roads.
- Below the toe of slopes.
- Along the site perimeter.
- In areas where sheet or rill flow occurs.
- Around temporary spoil areas.
- At sediment traps or culvert/pipe outlets.

INSTALLATION/APPLICATION CRITERIA:

- For rock filter, use larger rock and place in a staked, woven wire sheathing if placed where concentrated flows occur.
- Install along a level contour.
- Leave area behind berm where runoff can pond and sediment can settle.
- Drainage areas should not exceed 5 acres.

LIMITATIONS:

- Rock berms may be difficult to remove.
- Removal problems limit their usefulness in landscaped areas.
- Runoff will pond upstream of the filter, possibly causing flooding if sufficient space does not exist.

MAINTENANCE:

- Inspect monthly after each rainfall.
- If berm is damaged, reshape and replace lost/dislodged rock.
- Remove sediment when depth reaches 1/3 of berm height, or 1 ft.

TARGETED POLLUTANTS

- High Impact
- Medium Impact
- Low or Unknown Impact

- **Sediment**
 - Nutrients
 - Toxic Materials
 - Oil & Grease
 - Floatable Materials
 - Other Waste

IMPLEMENTATION REQUIREMENTS

- Capital Costs
- O&M Costs
- Maintenance
- Training

- High • Medium • Low

Materials Adapted From Salt Lake County Engineering Division Guidance Document



APPLICATIONS

- Manufacturing
- Material Handling
- Vehicle Maintenance
- Construction
- Commercial Activities
- Roadways
- Waste Containment
- Housekeeping Practices

DESCRIPTION:

Prevent or reduce the discharge of pollutants to stormwater from buildings and grounds maintenance by washing and cleaning up with as little water as possible, preventing and maintaining the stormwater collection system.

Buildings and grounds maintenance includes taking care of landscaped areas around the facility, cleaning of parking lots and pavement other than in the area of industrial activity, and the cleaning of the storm drainage system.

APPROACH:

- Preserve existing native vegetation to reduce water, fertilizer, and pesticide needs.
- Carefully use pesticides and fertilizers in landscaping.
- Integrate pest management where appropriate.
- Sweep paved surfaces.
- Clean the storm drainage system at appropriated intervals.
- Properly dispose of wash water, sweepings, and sediments.

LIMITATIONS:

Alternative pest/weed controls may not be available, suitable or effective in every case.

MAINTENANCE:

The BMPs themselves relate to maintenance and do not require maintenance as they do not involve structures.



TARGETED POLLUTANTS

- High Impact
- Low or Unknown Impact
- Medium Impact

- Sediment
- Nutrients
- Heavy Metals
- Toxic Materials
- Oxygen Demanding Substances
- Oil & Grease
- Floatable Materials
- Bacteria & Viruses

IMPLEMENTATION REQUIREMENTS

- Capital Costs
- O&M Costs
- Maintenance
- Training

- High
- Medium
- Low

Materials Adopted From Salt Lake County Engineering Division Guidance Document

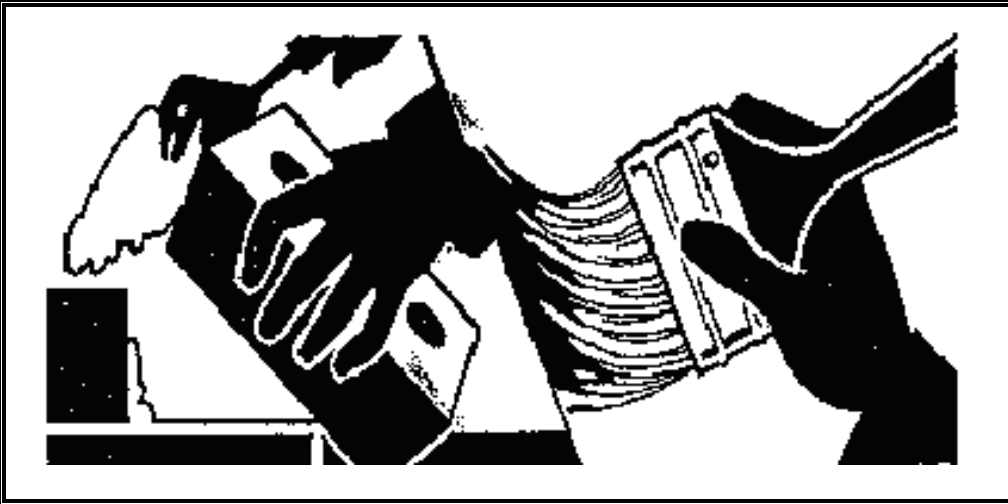

DESCRIPTION:

Prevent or reduce the discharge of pollutants to storm water from building repair, remodeling and construction by using soil erosion controls, enclosing or covering building material storage areas, using good housekeeping practices, using safer alternative products, and training employees.

APPLICATION:

- Use soil erosion control techniques if bare ground is temporarily exposed.
- Use permanent soil erosion control techniques if the remodeling clears buildings from an area that are not to be replaced.

INSTALLATION/APPLICATION CRITERIA:

- Enclose painting operations consistent with local air quality regulations and OSHA.
- Properly store materials that are normally used in repair and remodeling such as paints and solvents.
- Properly store and dispose waste materials generated from the activity.
- Maintain good housekeeping practices while work is underway.

LIMITATIONS:

- This BMP is for minor construction only.
- Hazardous waste that cannot be re-used or recycled must be disposed of by a licensed hazardous waste hauler.
- Safer alternative products may not be available, suitable, or effective in every case.
- Be certain that actions to help storm water quality are consistent with OSHA and air quality regulations.

MAINTENANCE:

None.

OBJECTIVES

- Housekeeping Practices
- Contain Waste
- Minimize Disturbed Areas
- Stabilize Disturbed Areas
- Protect Slopes/Channels
- Control Site Perimeter
- Control Internal Erosion



TARGETED POLLUTANTS

- High Impact
- Medium Impact
- Low or Unknown Impact

Sediment

- Nutrients
- Toxic Materials
- Oil & Grease
- Floatable Materials
- Other Waste

IMPLEMENTATION REQUIREMENTS

- Capital Costs
- O&M Costs
- Maintenance
- Training

- High
- Medium
- Low

Materials Adapted From Salt Lake County Engineering Division Guidance Document

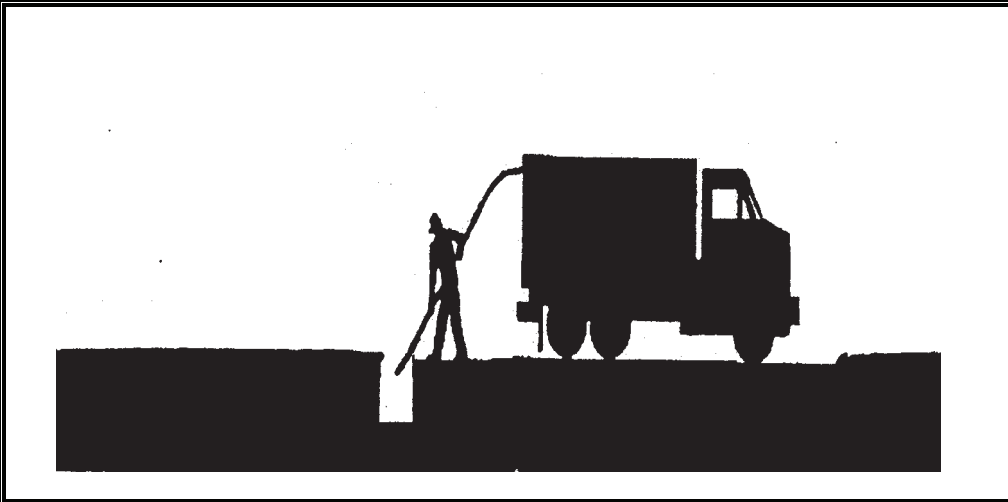

DESCRIPTION:

Maintain catch basin and stormwater inlets on a regular basis to remove pollutants, reduce high pollutant concentrations during the first flush of storms, prevent clogging of the downstream conveyance system, and restore the catch basins' sediment trapping capacity. A catch basin is distinguished from a stormwater inlet by having at its base a sediment sump designed to catch and retain sediments below the overflow point. This information sheet focuses on the cleaning of accumulated sediments from catch basins.

APPROACH:

Regular maintenance of catch basins and inlets is necessary to ensure their proper functioning. Clogged catch basins are not only useless but may act as a source of sediments and pollutants. In general, the key to effective catch basins are:

- At least annual inspections.
- Prioritize maintenance to clean catch basins and inlets in areas with the highest pollutant loading.
- Clean catch basins in high pollutant load areas just before the wet season to remove sediments and debris accumulated during the summer.
- Keep accurate logs of the number of catch basins cleaned.
- Record the amount of waste collected.

LIMITATIONS:

There are no major limitations to this best management practice.

MAINTENANCE:

Regular maintenance of public and private catch basins and inlets is necessary to ensure their proper functioning. Clogged catch basins are not only useless but may act as a source of sediments and pollutants. In general, the keys to effective catch basins are:

- Annual/monthly inspection of public and private facilities to ensure structural integrity, a clean sump, and a stenciling of catch basins and inlets.
- Keep logs of the number of catch basins cleaned.
- Record the amount of waste collected.

PROGRAM ELEMENTS

- New Development
- Residential
- Commercial Activities
- Industrial Activities
- Municipal Facilities
- Illegal Discharges



TARGETED POLLUTANTS

- High Impact
- Medium Impact
- Low or Unknown Impact

- Sediment
- Nutrients
- Heavy Metals
- Toxic Materials
- Oxygen Demanding Substances
- Oil & Grease
- Floatable Materials
- Bacteria & Viruses

IMPLEMENTATION REQUIREMENTS

- Capital Costs
- O&M Costs
- Regulatory
- Training
- Staffing
- Administrative

- High
- Medium
- Low

Materials Adopted From Salt Lake County Engineering Division Guidance Document

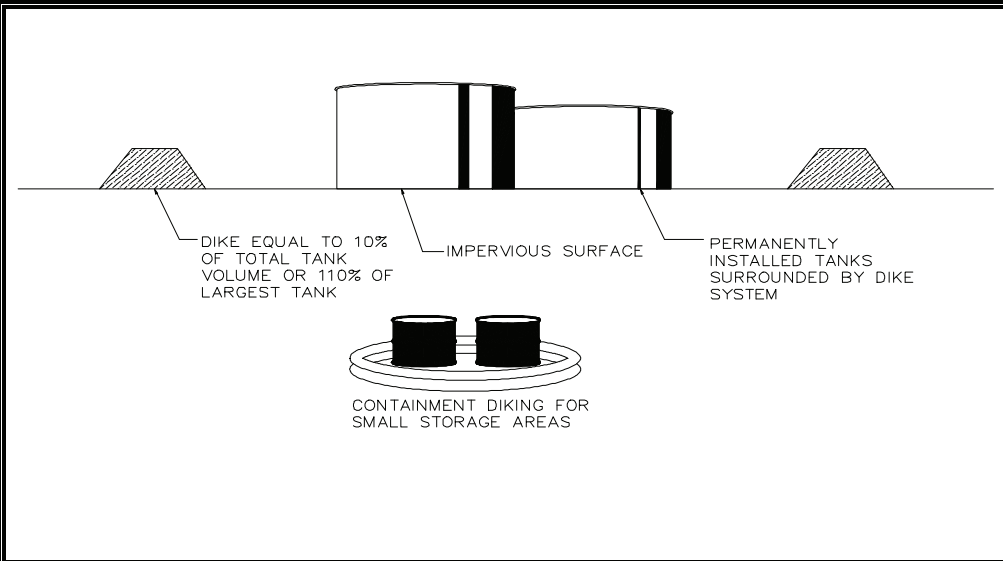

APPLICATIONS

- Manufacturing
- Material Handling
- Vehicle Maintenance
- Construction
- Commercial Activities
- Roadways
- Waste Containment
- Housekeeping Practices



DESCRIPTION:

Containment dikes are temporary or permanent earth or concrete berms or retaining walls that are designed to hold spills. Diking, one of the most common types of containment, is an effective method of pollution prevention for above-ground liquid storage tanks and rail car or tank truck loading and unloading areas. Diking can provide one of the best protective measures against the contamination of stormwater because it surrounds the area of concern and holds the spill, keeping spill materials separated from the stormwater outside of the diked area.

APPROACH:

- Containment dikes should be large enough to hold an amount equal to the largest single storage tank at the particular facility plus the volume of rainfall or 10% of total tank volume.
- Materials used to construct the dike should be strong enough to safely hold spilled materials. Materials used usually depend on what is available onsite and the substance to be contained. The material may consist of earth (i.e., soil or clay), concrete, synthetic materials (liners), metal, or other impervious materials.
- Containment dikes may need to be designed with impervious materials to prevent leaking or contamination of stormwater, surface, and ground water supplies.
- Uncontrolled overflows from diked areas containing spilled materials or contaminated stormwater should be prevented to protect nearby surface and ground waters. Therefore, dikes should have either pumping systems or vacuum trucks available to remove the spilled materials.

LIMITATIONS:

- May be too expensive for small facilities.
- Could collect contaminated stormwater, possibly resulting in infiltration of stormwater to ground water.

MAINTENANCE:

Inspections should be conducted during or after significant storms or spills to check for washouts or overflows. In addition, regular checks of containment dikes (i.e., testing to ensure that dikes are capable of holding spills) is recommended.

TARGETED POLLUTANTS

- High Impact
- Medium Impact
- Low or Unknown Impact

- Sediment
- Nutrients
- Heavy Metals
- Toxic Materials
- Oxygen Demanding Substances
- Oil & Grease
- Floatable Materials
- Bacteria & Viruses

IMPLEMENTATION REQUIREMENTS

- Capital Costs
- O&M Costs
- Maintenance
- Training

- High
- Medium
- Low

Materials Adopted From Salt Lake County Engineering Division Guidance Document

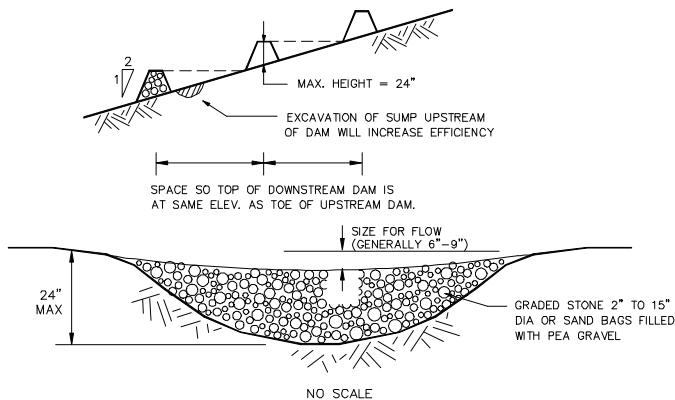

OBJECTIVES

- Housekeeping Practices
- Contain Waste
- Minimize Disturbed Areas
- Stabilize Disturbed Areas
- Protect Slopes/Channels
- Control Site Perimeter
- Control Internal Erosion

DESCRIPTION:

A small, temporary dam constructed across a drainage ditch to reduce velocity of concentrated storm water flows, thereby reducing the erosion of the ditch.

APPLICATION:

- Temporary drainage paths
- Permanent drainage ways not yet stabilized
- Existing drainage paths receiving increased flows due to construction

INSTALLATION/APPLICATION CRITERIA:

- Prepare location of dam by removing any debris and rough grading any irregularities in channel bottom
- Place rocks by hand or with appropriate machinery, do not dump
- Construct dam with center lower to pass design flow
- Construct 50% side slopes on dam

LIMITATIONS:

- Maximum recommended drainage area is 10 acres
- Maximum recommended height is 24"
- Do not use in running stream

MAINTENANCE:

- Inspect dams daily during prolonged rainfall, after each major rain event and at a minimum of once monthly.
- Remove any large debris and repair any damage to dam, channel or sideslopes
- Remove accumulated sediment when it reaches one half the height of the dam



TARGETED POLLUTANTS

- High Impact
- Medium Impact
- Low or Unknown Impact

Sediment

- Nutrients
- Toxic Materials
- Oil & Grease
- Floatable Materials
- Other Waste

IMPLEMENTATION REQUIREMENTS

- Capital Costs
- O&M Costs
- Maintenance
- Training

- High
- Medium
- Low

MATERIALS ADAPTED FROM SALT LAKE COUNTY ENGINEERING DIVISION GUIDANCE DOCUMENT



OBJECTIVES

- Housekeeping Practices
- Contain Waste
- Minimize Disturbed Areas
- Stabilize Disturbed Areas
- Protect Slopes/Channels
- Control Site Perimeter
- Control Internal Erosion



DESCRIPTION:

Prevent or reduce the discharge of pollutants to storm water from contaminated or erodible surface areas by leaving as much vegetation on-site as possible, minimizing soil exposure time, stabilizing exposed soils, and preventing storm water runoff and runoff.

APPLICATION:

This BMP addresses soils which are not so contaminated as to exceed criteria but the soil is eroding and carrying pollutants off in the storm water.

INSTALLATION/APPLICATION CRITERIA:

Contaminated or erodible surface areas can be controlled by: Preservation of natural vegetation, re-vegetation, chemical stabilization, removal of contaminated soils or geosynthetics.

LIMITATIONS:

- Disadvantages of preserving natural vegetation or re-vegetating include:
- Requires substantial planning to preserve and maintain the existing vegetation.
 - May not be cost-effective with high land costs.
 - Lack of rainfall and/or poor soils may limit the success of re-vegetated areas.
 - Disadvantages of chemical stabilization include:
 - Creation of impervious surfaces.
 - May cause harmful effects on water quality.
 - Is usually more expensive than vegetative cover.

MAINTENANCE:

Maintenance should be minimal, except possibly if irrigation of vegetation is necessary.

TARGETED POLLUTANTS

- High Impact
- Medium Impact
- Low or Unknown Impact

- Sediment
- Nutrients
- Toxic Materials
- Oil & Grease
- Floatable Materials
- Other Waste

IMPLEMENTATION REQUIREMENTS

- Capital Costs
- O&M Costs
- Maintenance
- Training

- High
- Medium
- Low

Materials Adapted From Salt Lake County Engineering Division Guidance Document

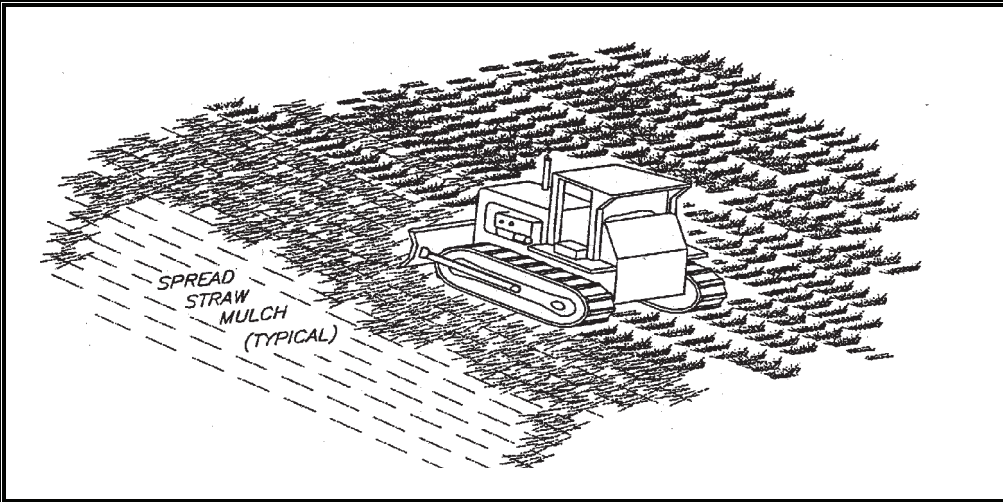

DESCRIPTION:

Applying materials such as vinyl, asphalt, plastics, or rubber on an unprotected slope to temporarily stabilize the slope.

APPLICATIONS:

- As a tacking agent to aid the stabilization of mulches (where matting is not used).
- As a short-term alternative in areas where temporary seeding practices cannot be used because of seasonal condition or climate.
- On steep and rocky slopes where neither mechanical methods or mulches and protective netting can be effectively applied.

INSTALLATION/APPLICATION CRITERIA:

- The application rates and procedures recommended by the manufacturer of a chemical stabilization product should be followed to prevent the products from forming ponds and from creating large areas where moisture cannot get through.
- For permanent application, chemical mulches (when used with seed and mulch) should be applied over wood fiber or straw mulch.

LIMITATIONS:

- Chemical mulches can create impervious surfaces and impact water quality if not properly applied.
- Some products may not be suitable for use near live streams.

MAINTENANCE:

- Inspect at regular intervals and after each runoff-producing storm event.
- Replace chemical mulch as needed to ensure adequate level of coverage.

OBJECTIVES

- Housekeeping Practices
- Contain Waste
- Minimize Disturbed Areas
- Stabilize Disturbed Areas
- Protect Slopes/Channels
- Control Site Perimeter
- Control Internal Erosion



TARGETED POLLUTANTS

- High Impact
- Medium Impact
- Low or Unknown Impact

■ **Sediment**

- Nutrients
- Toxic Materials
- Oil & Grease
- Floatable Materials
- Other Waste

IMPLEMENTATION REQUIREMENTS

- Capital Costs
- O&M Costs
- Maintenance
- Training

- High
- Medium
- Low

Materials Adapted From Salt Lake Country Engineering Division Guidance Document

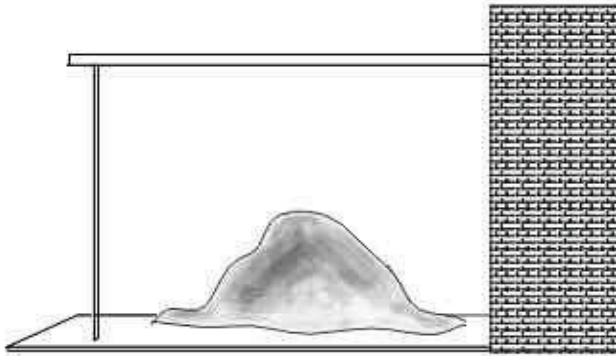

APPLICATIONS

- Manufacturing
- Material Handling
- Vehicle Maintenance
- Construction
- Commercial Activities
- Roadways
- Waste Containment
- Housekeeping Practices



DESCRIPTION:

Covering is the partial or total physical enclosure of materials, equipment, process operations, or activities. Covering certain areas or activities prevents stormwater from coming into contact with potential pollutants and reduces material loss from wind blowing. Tarpaulins, plastic sheeting, roofs, buildings, and other enclosures are examples of covering that are effective in preventing stormwater contamination. Covering can be temporary or permanent.

APPROACH:

- Covering is appropriate for outdoor material storage piles (e.g., stockpiles of dry materials, gravel, sand, compost, sawdust, wood chips, and de-icing salt) as well as areas where liquids and solids in containers are stored or transferred.
- While it may be too expensive to cover all industrial activities, cover all high-risk areas first (e.g., chemical preparation areas, vehicle maintenance areas, and areas where salts are stored), then according to budget cover the rest of the materials.
- Evaluate the strength and longevity of the covering, as well as its compatibility with the material or activity being enclosed.
- When designing an enclosure, consider access to materials, their handling, and transfer.
- Materials that pose environmental and safety dangers require special ventilation and temperature considerations.
- Covering alone may not protect the materials. When designing, consider placing materials on an elevated, impermeable surface or build curbing around the outside of the materials to prevent problems from runoff of uncontaminated stormwater from adjacent areas.
- Anchor all coverings with stakes, tie-down ropes, large rocks, tires or other easily available heavy objects.

LIMITATIONS:

- Requires frequent inspection.
- May pose health or safety problems if enclosure is built over certain activities.

MAINTENANCE:

- Frequently inspect coverings for rips, holes and general wear.

TARGETED POLLUTANTS

- High Impact
 - Medium Impact
 - Low or Unknown Impact

- Sediment
- Nutrients
- Heavy Metals
- Toxic Materials
- Oxygen Demanding Substances
- Oil & Grease
- Floatable Materials
- Bacteria & Viruses

IMPLEMENTATION REQUIREMENTS

- Capital Costs
- O&M Costs
- Maintenance
- Training

- High
- Medium
- Low

Materials Adopted From Salt Lake County Engineering Division Guidance Document

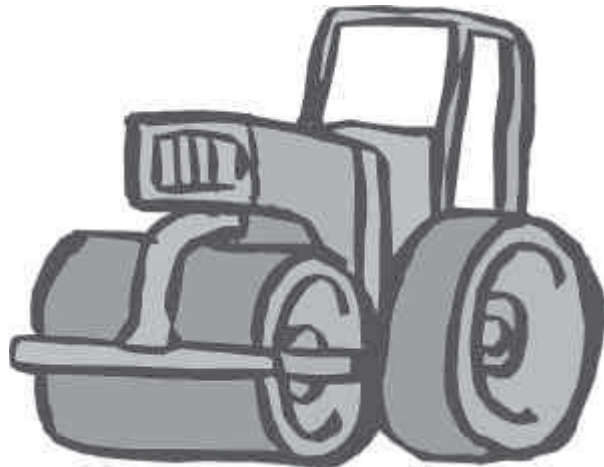

OBJECTIVES

- Housekeeping Practices
- Contain Waste
- Minimize Disturbed Areas
- Stabilize Disturbed Areas
- Protect Slopes/Channels
- Control Site Perimeter
- Control Internal Erosion



DESCRIPTION:

Use of rolling, tamping, or vibration to stabilize fill materials and control erosion by increasing the soil density. Increasing the density of soil improves soil strength, reduces long-term soil settlement, and provides resistance to erosion.

APPLICATIONS:

- Stabilize fill material placed around various structures.
- Improve soil in place as foundation support for roads, parking lots, and buildings.

INSTALLATION/APPLICATION CRITERIA:

- Make sure soil moisture content is at optimum levels.
- Use proper compaction equipment.
- Install sediment control and storm water management devices below compacted areas and runoff interceptor devices above these areas. Drainage from compacted areas must be carefully planned to protect adjacent uncompacted soils.
- The surface of compacted areas should be scarified and seeded or mulched and seeded to increase the effectiveness of compaction.

LIMITATIONS:

- Compaction tends to increase runoff.
- Over-compaction will hamper revegetation efforts.

MAINTENANCE:

No maintenance required.

TARGETED POLLUTANTS

- High Impact
- Medium Impact
- Low or Unknown Impact

- Sediment
- Nutrients
- Toxic Materials
- Oil & Grease
- Floatable Materials
- Other Waste

IMPLEMENTATION REQUIREMENTS

- Capital Costs
- O&M Costs
- Maintenance
- Training

- High
- Medium
- Low

Materials Adapted From Salt Lake County Engineering Division Guidance Document

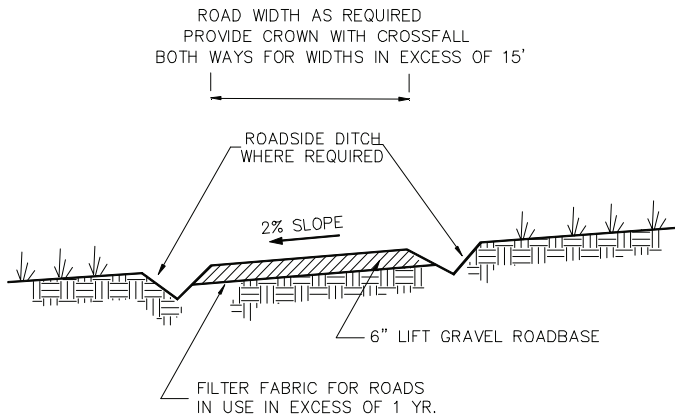

OBJECTIVES

- Housekeeping Practices
- Contain Waste
- Minimize Disturbed Areas
- Stabilize Disturbed Areas
- Protect Slopes/Channels
- Control Site Perimeter
- Control Internal Erosion

DESCRIPTION:

Temporary stabilization of on-site roadway by placement of gravel roadbase.

APPLICATION:

- On-site roadways used daily by construction traffic (may not apply to gravelly type soils)
- Parking or staging areas susceptible to erosion due to traffic use

INSTALLATION/APPLICATION CRITERIA:

- Grade temporary access road with 2% cross fall, for two-way width provide crown.
- Provide roadside ditch and outlet controls where required.
- Place 6 inches of 2-inch to 4-inch crushed rock on driving area

LIMITATIONS:

- May require removal of gravel roadbase at completion of activities if final cover is not impervious
- May require controls for surface storm water runoff

MAINTENANCE:

- Inspect after major rainfall events and at least monthly.
- Place additional gravel as needed and repair any damaged areas.
- Maintain any roadside drainage controls.



TARGETED POLLUTANTS

- High Impact
- Medium Impact

- Sediment
- Nutrients
- Toxic Materials
- Oil & Grease
- Floatable Materials
- Other Waste

IMPLEMENTATION REQUIREMENTS

- Capital Costs
- O&M Costs
- Maintenance
- Training

- High
- Medium
- Low

Materials Adopted From Salt Lake County Engineering Division Guidance Document

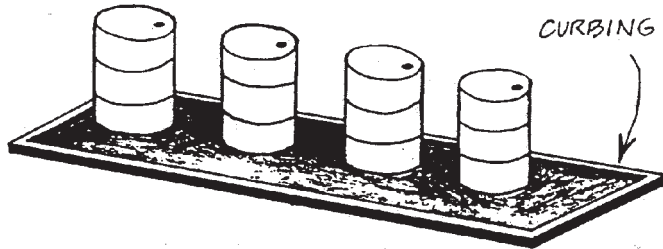

APPLICATIONS

- Manufacturing
- Material Handling
- Vehicle Maintenance
- Construction
- Commercial Activities
- Roadways
- Waste Containment
- Housekeeping Practices

DESCRIPTION:

Curbing is a barrier that surrounds an area of concern, much like containment diking (See Containment Diking BMP). Curbing prevents spills, leaks, etc. from being released to the environment by routing runoff to treatment or control areas. The terms curbing and diking are sometimes used interchangeably.

APPROACH:

- Curbing can be used at all industrial facilities. It is particularly useful in areas where liquid materials are transferred and as a stormwater runoff control.
- As with diking, common materials for curbing include earth, concrete, synthetic materials, metal, or other impenetrable materials. Asphalt is also a common material used in curbing.
- For maximum efficiency, spilled materials should be removed immediately, to allow space for future spills.
- Curbs should have pumping systems, instead of drainage systems, for collecting spilled materials.
- Curb systems should be maintained through curb repair (patching and replacement).
- To minimize the amount of spilled material tracked outside of the area by personnel, grade within the curbing to direct the spilled materials to a down-slope side of the curbing, thus keeping the spilled materials away from personnel and equipment. Grading will also facilitate clean-up.

LIMITATIONS:

- Curbing is not effective for holding large spills.
- May require more maintenance than diking.

MAINTENANCE:

- Inspection should be conducted before and after storm events.
- When certain spills occur, cleanup should start immediately, thus preventing overflows and contamination of stormwater runoff.
- Inspection should also be made to clear clogging debris, prevent dilution by rainwater, and to again prevent overflow of any materials.



TARGETED POLLUTANTS

- High Impact
- Medium Impact
- Low or Unknown Impact
- Sediment
- Nutrients
- Heavy Metals
- Toxic Materials
- Oxygen Demanding Substances
- Oil & Grease
- Floatable Materials
- Bacteria & Viruses

IMPLEMENTATION REQUIREMENTS

- Capital Costs
- O&M Costs
- Maintenance
- Training

- High
- Medium
- Low

Materials Adopted From Salt Lake County Engineering Division Guidance Document

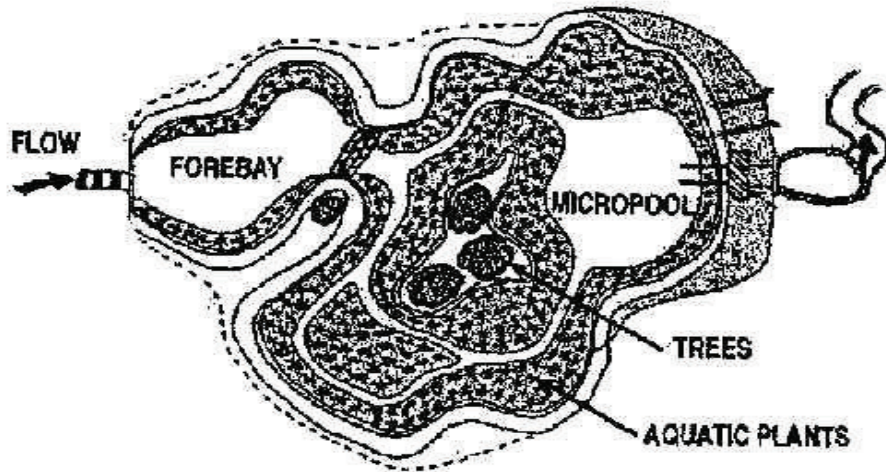

CONSIDERATIONS

- Soils
- Area Required
- Slope
- Water Availability
- Aesthetics
- Hydraulic Head
- Environmental Side Effects

DESCRIPTION:

Constructed wetlands have a significant percentage of the facility covered by wetland vegetation.

APPLICATION:

- Need to achieve high level of particulate and some dissolved contaminant removal.
- Ideal for large, regional tributary areas.
- Multiple benefits of passive recreation and wildlife.

INSTALLATION/APPLICATION CRITERIA:

- Suitable soils for wetland vegetation are required.
- Surface area equal to at least 1% and preferably 2% of the tributary watershed.
- Involve qualified wetland ecologist to design and install wetland vegetation.
- Establishing wetland vegetation may be difficult.

LIMITATIONS:

- Concern for mosquitos.
- Cannot be placed on steep unstable slopes.
- Need base flow to maintain water level.
- Not feasible in densely developed areas.
- Nutrient release may occur during winter.
- Overgrowth can lead to reduced hydraulic capacity.
- Regulatory agencies may limit water quality to constructed wetlands.

MAINTENANCE:

- Remove foreign debris and sediment build-up.
- Areas of bank erosion should be repaired.
- Remove nuisance species.
- Control mosquitos.



TARGETED POLLUTANTS

- High Impact
- Medium Impact
- Low or Unknown Impact

- Sediment
- Nutrients
- Heavy Metals
- Toxic Materials
- Oxygen Demanding Substances
- Oil & Grease
- Floatable Materials
- Bacteria & Viruses

IMPLEMENTATION REQUIREMENTS

- Capital Costs
- O&M Costs
- Maintenance
- Training

- High
- Medium
- Low

Materials Adopted From Salt Lake County Engineering Division Guidance Document

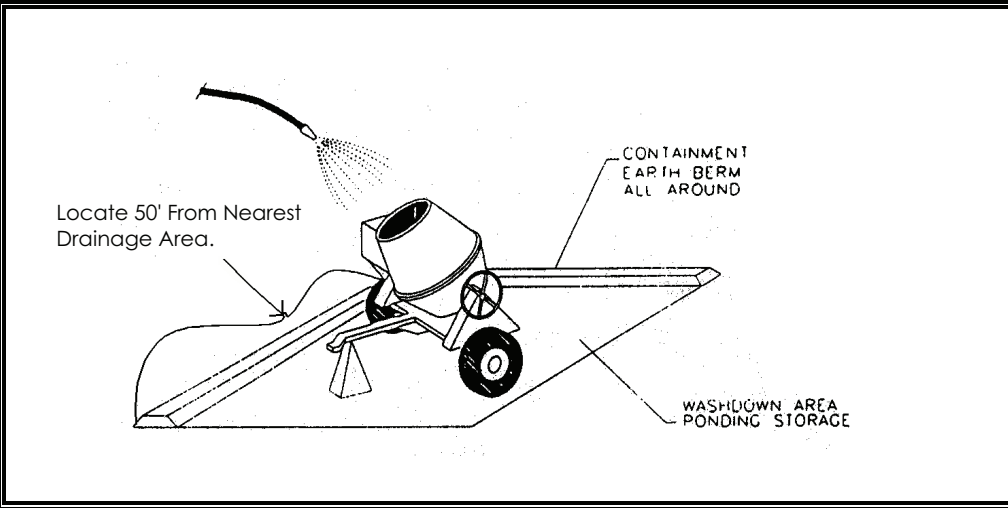

DESCRIPTION:

Prevent or reduce the discharge of pollutants to storm water from concrete waste by conducting washout off-site, performing on-site washout in a designated area, and training employees and subcontractors.

APPLICATIONS:

This technique is applicable to all types of sites.

INSTALLATION/APPLICATION CRITERIA:

- Store dry and wet materials under cover, away from drainage areas.
- Avoid mixing excess amounts of fresh concrete or cement on-site.
- Perform washout of concrete trucks off-site or in designated areas only.
- Do not wash out concrete trucks into storm drains, open ditches, streets, or streams.
- Do not allow excess concrete to be dumped on-site, except in designated areas.
- When washing concrete to remove fine particles and expose the aggregate, avoid creating runoff by draining the water within a bermed or level area. (See Earth Berm Barrier information sheet.)
- Train employees and subcontractors in proper concrete waste management.

LIMITATIONS:

- Off-site washout of concrete wastes may not always be possible.

MAINTENANCE:

- Inspect subcontractors to ensure that concrete wastes are being properly managed.
- If using a temporary pit, dispose hardened concrete on a regular basis.

OBJECTIVES

- Housekeeping Practices
- Contain Waste
- Minimize Disturbed Areas
- Stabilize Disturbed Areas
- Protect Slopes/Channels
- Control Site Perimeter
- Control Internal Erosion



TARGETED POLLUTANTS

- High Impact
- Medium Impact
- Low or Unknown Impact

- Sediment
- Nutrients
- Toxic Materials
- Oil & Grease
- Floatable Materials
- Other Waste

IMPLEMENTATION REQUIREMENTS

- Capital Costs
- O&M Costs
- Maintenance
- Training

- High
- Medium
- Low

Materials Adopted from Salt Lake County Engineering Division Guidance Document

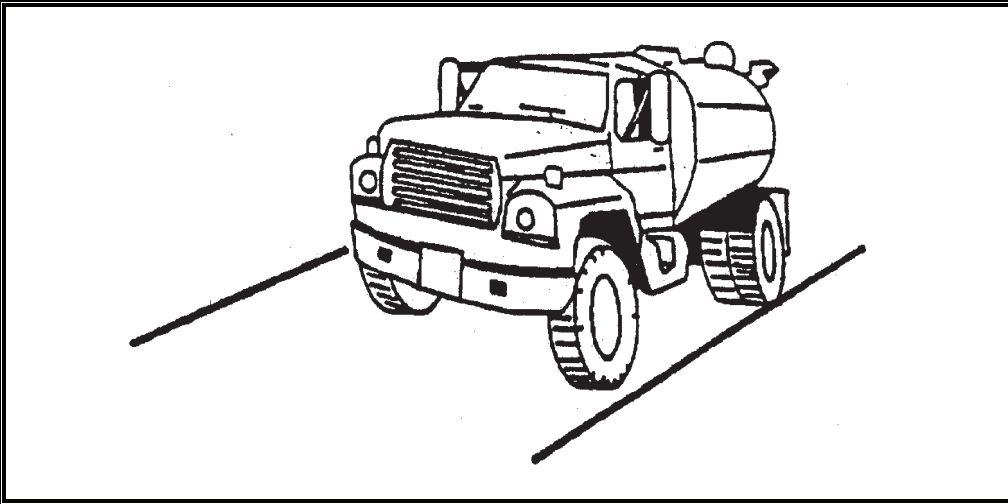

OBJECTIVES

- Housekeeping Practices
- Contain Waste
- Minimize Disturbed Areas
- Stabilize Disturbed Areas
- Protect Slopes/Channels
- Control Site Perimeter
- Control Internal Erosion



DESCRIPTION:

Dust control measures are used to stabilize soil from wind erosion, and reduce dust by construction activities.

APPLICATION:

Dust control is useful in any process area, loading and unloading area, material handling areas, and transfer areas where dust is generated. Street sweeping is limited to areas that are paved.

INSTALLATION/APPLICATION CRITERIA:

- Mechanical dust collection systems are designed according to the size of dust particles and the amount of air to be processed. Manufacturers' recommendations should be followed for installation (as well as the design of the equipment).
- Two kinds of street sweepers are common: brush and vacuum. Vacuum sweepers are more efficient and work best when the area is dry.
- Mechanical equipment should be operated according to the manufacturers' recommendations and should be inspected regularly.

LIMITATIONS:

- Is generally more expensive than manual systems.
- May be impossible to maintain by plant personnel (the more elaborate equipment).
- Is labor and equipment intensive and may not be effective for all pollutants (street sweepers).

MAINTENANCE:

If water sprayers are used, dust-contaminated waters should be collected and taken for treatment. Areas will probably need to be resprayed to keep dust from spreading.

TARGETED POLLUTANTS

- High Impact
- Medium Impact
- Low or Unknown Impact

- Sediment
- Nutrients
- Toxic Materials
- Oil & Grease
- Floatable Materials
- Other Waste

IMPLEMENTATION REQUIREMENTS

- Capital Costs
- O&M Costs
- Maintenance
- Training

- High
- Medium
- Low

Materials Adopted From Salt Lake County Engineering Division Guidance Document

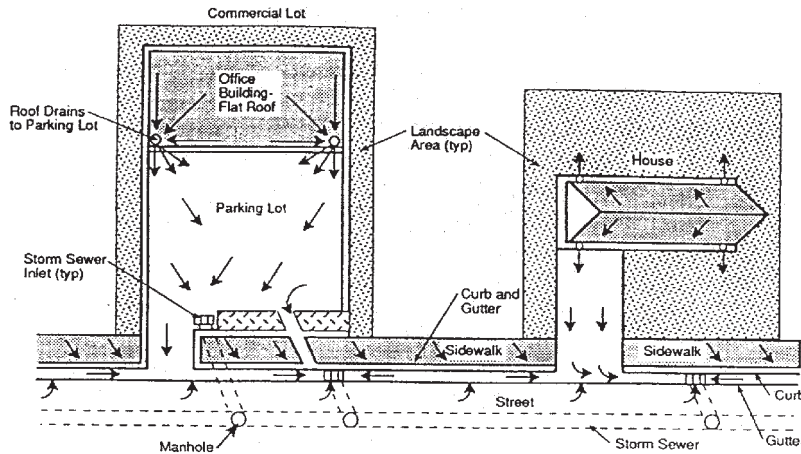

CONSIDERATIONS

- Soils
- Area Required
- Slope
- Water Availability
- Aesthetics
- Hydraulic Head
- Environmental Side Effects

DESCRIPTION:

Minimizing directly connected impervious areas (DCIAs) is a structural BMP strategy that requires a basic change in drainage design philosophy. The basic principle is to direct stormwater runoff to landscaped areas, grass buffer strips, and vegetated swales to slow down the rate of runoff, reduce runoff volumes, attenuate peak flows, and encourage filtering and infiltration of stormwater.

APPLICATION:

It can be made an integral part of drainage planning for any development.

INSTALLATION/APPLICATION CRITERIA:

- Use on sites with general terrain slopes flatter than 3-4%.
- Design the site drainage flowpath to maximize flow over vegetated areas before leaving a site.
- Minimize ground slopes to limit erosion and slow down water flow.
- Select vegetation that will not only survive, but also enhance water quality.

LIMITATIONS:

- Potential increase in site open space requirements over the traditional development systems.
- Introduction of a nonconventional development design strategy.
- Infiltration of water near building foundations and parking lots is a concern.
- Will likely result in increased maintenance along the swales.

MAINTENANCE:

- Maintain grass and other vegetation.
- Pick up debris.
- Conduct ongoing inspections for potential erosion problems and changes in drainage patterns.
- Remove sediment buildup and replace damaged grass cover.



TARGETED POLLUTANTS

- High Impact
 - Medium Impact
 - Low or Unknown Impact

- Sediment
- Nutrients
- Heavy Metals
- Toxic Materials
- Oxygen Demanding Substances
- Oil & Grease
- Floatable Materials
- Bacteria & Viruses

IMPLEMENTATION REQUIREMENTS

- Capital Costs
- O&M Costs
- Maintenance
- Training

- High • Medium • Low

Materials Adopted From Salt Lake County Engineering Division Guidance Document



APPLICATIONS

- Manufacturing
- Material Handling
- Vehicle Maintenance
- Construction
- Commercial Activities
- Roadways
- Waste Containment
- Housekeeping Practices

DESCRIPTION:

A sizeable amount of de-icing chemicals are used each winter on roads, parking lots, and sidewalks in Utah. Sodium chloride (salt) is the main chemical used. Proper use and storage of salt will reduce the chance of high chloride concentration in runoff that may damage the environment.

APPROACH:

- Proper storage practices can control sodium chloride pollution in runoff from stockpiles.
- For de-icing use, preventing over-application of salt will reduce quantities of chloride reaching surface or ground water.
- All salt piles should be covered with polyethylene if not stored in a shed. All sand/salt piles should be moved to empty salt sheds or covered during the spring and summer.
- Any runoff from stockpiles should be contained.
- To prevent over-application of salt one must properly calibrate the equipment and monitor the need for de-icing material.
- Another method to prevent the over-application of salt is to limit salt application on low traffic areas and straight level areas, critical areas will, however, need higher levels of service.

LIMITATIONS:

- All deicers hold the potential for damaging grass and plant biota should their concentration within the soil becomes unusually high. In amounts recommended for sidewalk and driveway deicing, there is minimal chance of damage to trees, grass, and shrubs. This is especially true if the chemical is used sparingly -- only to undercut snow and ice -- and the slush is not plowed or shoveled into grassy or planted areas.
- Another concern of many businesses and homeowners is the visible deicer residue that may be tracked into a building. This residue occurs because these deicers are solids in their natural state. However, since the residue is water soluble, it cleans up readily using plain water or ordinary household cleaner.
- Salt should not be used to melt every bit of snow and ice. Use only enough to break the ice/pavement bond, then remove the remaining slush by plowing or shoveling.



TARGETED POLLUTANTS

- High Impact
 - Medium Impact
 - Low or Unknown Impact
-
- Sediment
 - Nutrients
 - Heavy Metals
 - Toxic Materials
 - Oxygen Demanding Substances
 - Oil & Grease
 - Floatable Materials
 - Bacteria & Viruses

IMPLEMENTATION REQUIREMENTS

- Capital Costs
 - O&M Costs
 - Maintenance
 - Training
-
- High • Medium • Low

Materials Adopted From Salt Lake County Engineering Division Guidance Document

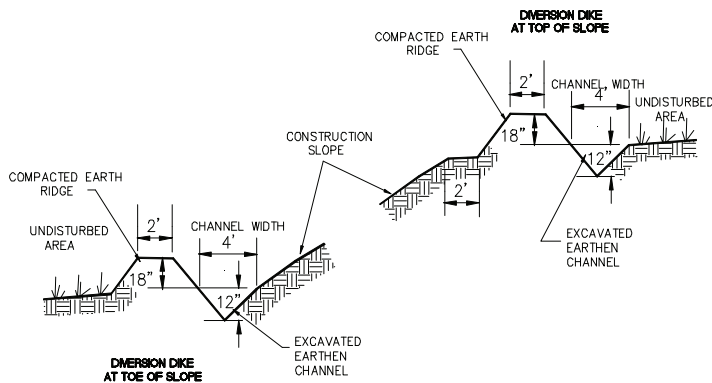

OBJECTIVES

- Housekeeping Practices
- Contain Waste
- Minimize Disturbed Areas
- Stabilize Disturbed Areas
- Protect Slopes/Channels
- Control Site Perimeter
- Control Internal Erosion

DESCRIPTION:

A temporary sediment barrier and storm runoff conveyance consisting of an excavation channel and compacted earth ridge.

APPLICATION:

- Construct along top of construction slope to intercept upgradient runoff and convey around construction site.
- Construct along toe of construction to divert sediment laden runoff.
- Construct along midpoint of construction slope to intercept runoff and channel to controlled discharge point.
- Construct around base of soil stockpiles to capture sediment.
- Construct around perimeter of disturbed areas to capture sediment.

INSTALLATION/APPLICATION CRITERIA:

- Clear and grub area for dike construction.
- Excavate channel and place soil on downgradient side.
- Shape and machine compact excavated soil to form ridge.
- Place erosion protection (riprap, mulch) at outlet.
- Stabilize channel and ridge as required with mulch, gravel, or vegetative cover.

LIMITATIONS:

- Recommended maximum drainage area of 5 acres
- Recommended maximum sideslopes of 2h:1v (50%)
- Recommended maximum slope on channel of 1%

MAINTENANCE:

- Inspect immediately after any rainfall and at least daily during prolonged rainfall.
- Look for runoff breaching dike or eroding channel or sideslopes.
- Check discharge point for erosion or bypassing of flows.
- Repair and stabilize as necessary.
- Inspect daily during vehicular activity on slope, check for and repair any traffic damage.



TARGETED POLLUTANTS

- High Impact
- Medium Impact
- Low or Unknown Impact

- Sediment
- Nutrients
- Toxic Materials
- Oil & Grease
- Floatable Materials
- Other Waste

IMPLEMENTATION REQUIREMENTS

- Capital Costs
- O&M Costs
- Maintenance
- Training

- High
- Medium
- Low

MATERIALS ADOPTED FROM SALT LAKE COUNTY ENGINEERING DIVISION GUIDANCE DOCUMENT

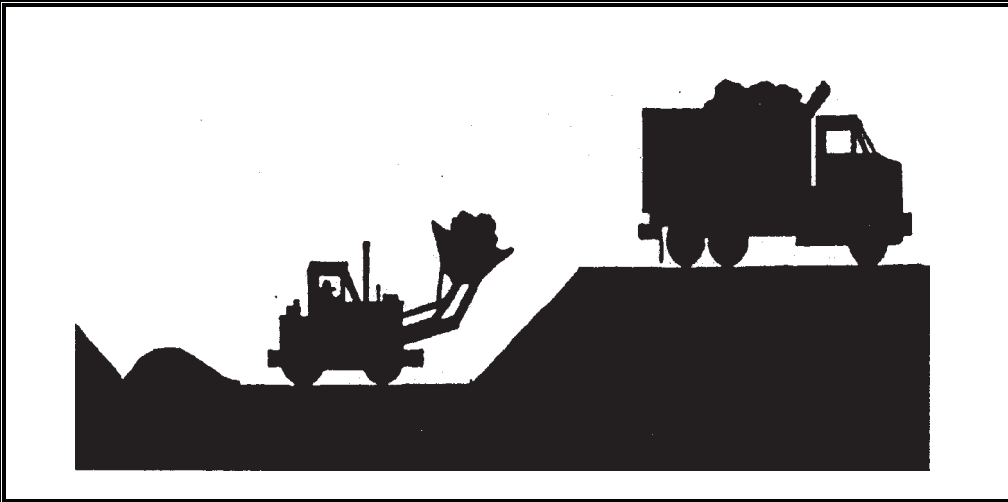

DESCRIPTION:

Proper maintenance and siltation removal is required on both a routine and corrective basis to promote effective stormwater pollutant removal efficiencies for wet/dry detention pond and infiltrative devices.

APPROACH:

- Remove silt after sufficient accumulation.
- Periodically clean accumulated sediment and silt out of pre-treatment inlets.
- Infiltration device silt removal should occur when the infiltration rate drops below 1/2 inch per hour.
- Removal of accumulated paper, trash, and debris should occur every six months or as needed to prevent clogging of control devices.
- Vegetation growth should not be allowed to exceed 18 inches in height.
- Mow the slopes periodically and check for clogging, erosion and tree growth on the embankment.
- Corrective maintenance may require more frequent attention (as required).
- Create a public education campaign to explain the function of wet/dry detention pond/infiltration devices and their operation requirements for proper effectiveness.
- Encourage the public to report wet/dry detention pond/infiltration devices needing maintenance.

LIMITATIONS:

- Wet detention pond dredging can produce slurred waste that often exceeds the requirements of many landfills.
- Frequent sediment removal is labor and cost intensive.

PROGRAM ELEMENTS

- New Development
- Residential
- Commercial Activities
- Industrial Activities
- Municipal Facilities
- Illegal Discharges



TARGETED POLLUTANTS

- High Impact
- Medium Impact
- Low or Unknown Impact

- Sediment
- Nutrients
- Heavy Metals
- Toxic Materials
- Oxygen Demanding Substances
- Oil & Grease
- Floatable Materials
- Bacteria & Viruses

IMPLEMENTATION REQUIREMENTS

- Capital Costs
- O&M Costs
- Regulatory
- Training
- Staffing
- Administrative

- High
- Medium
- Low

Materials Adopted From Salt Lake County Engineering Division Guidance Document

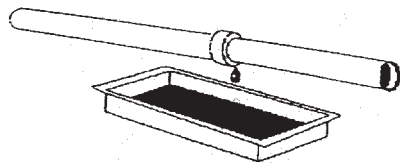

Use Drip Pans for Leaking Equipment

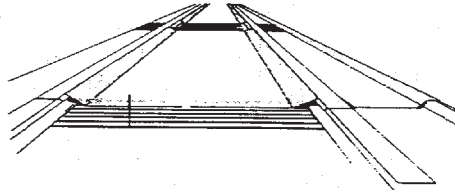

Use Drip Pans in Loading and Unloading Areas

APPLICATIONS

- Manufacturing
- Material Handling
- Vehicle Maintenance
- Construction
- Commercial Activities
- Roadways
- Waste Containment
- Housekeeping Practices



DESCRIPTION:

Drip pans are small depressions or pans used to contain very small volumes of leaks, drips, and spills that occur at a facility. Drip pans can be depressions in concrete, asphalt, or other impenetrable material. They can be made of metal, plastic, or any material that does not react with the dripped chemicals. Drip pans can be temporary or permanent.

Drip pans are used to catch drips from valves, pipes, etc. so that the materials or chemicals can be cleaned up easily or recycled before they contaminate stormwater. Although leaks and drips should be repaired and eliminated as part of a preventative maintenance program, drip pans can provide a temporary solution where repair or replacement must be delayed. In addition, drip pans can be an added safeguard when they are positioned beneath areas where leaks and drips may occur.

APPROACH:

- When using drip pans, consider the location of the drip pan, weather conditions, the type of material used for the drip pan, and how it will be cleaned.
- The location of the drip pan is important. Because drip pans must be inspected and cleaned frequently, they must be easy to reach and remove. However, take special care to avoid placing drip pans where they can be easily overturned or be a safety hazard.
- Secure pans by installing or anchoring them. Drip pans may be placed on platforms, behind wind blocks or tied down.
- Employees must pay attention to the pans and empty them when they are nearly full.
- Frequent inspection of the drip pans is necessary due to the possibility of leaks in the pan itself or in piping or valves that may occur randomly or irregular slow drips that may increase in volume.

LIMITATIONS:

- Contain small volumes only.
- Must be inspected and cleaned frequently.
- Must be secured during poor weather conditions.
- Contents may be disposed of improperly unless facility personnel are trained in proper disposal methods.

TARGETED POLLUTANTS

- High Impact
- Medium Impact
- Low or Unknown Impact

- Sediment
- Nutrients
- Heavy Metals
- Toxic Materials
- Oxygen Demanding Substances
- Oil & Grease
- Floatable Materials
- Bacteria & Viruses

IMPLEMENTATION REQUIREMENTS

- Capital Costs
- O&M Costs
- Maintenance
- Training

- High
- Medium
- Low

Materials Adopted From Salt Lake County Engineering Division Guidance Document

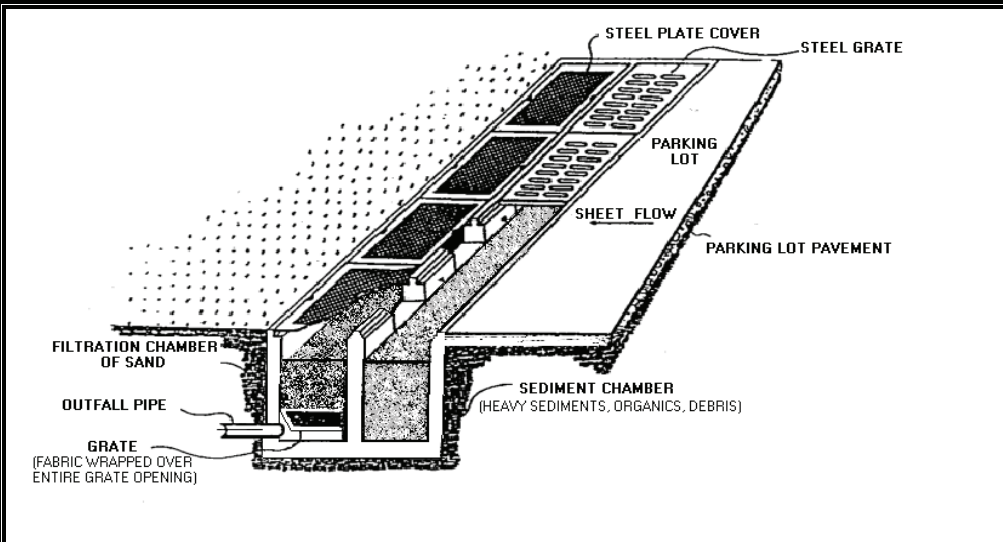

CONSIDERATIONS

- Soils
- Area Required
- Slope
- Water Availability
- Aesthetics
- Hydraulic Head



DESCRIPTION:

The double trench sand filter (AKA Delaware sand filter) is a BMP consisting of parallel sedimentation and sand filter trenches connected by a series of level weir notches to assure sheet flow onto the filter. Filtered runoff is conveyed to a storm sewer by gravity flow or by pumping.

APPLICATION:

- Commercial and institutional parking lots, small shopping centers, infill developments.
- Smaller redevelopment sites where the use of conventional BMPs is not practical.

INSTALLATION/APPLICATION CRITERIA:

- Requires very little hydraulic head.
- Need to consider structural design with traffic load.

LIMITATIONS:

- Will not prevent small floatable debris from entering through the grate openings.
- Disposing of petroleum-contaminated sand may require expertise in hazardous waste disposal.
- Sand filter may clog sooner than other BMPs requiring more frequent maintenance.

MAINTENANCE:

- System should be inspected yearly and after storm events to assess the filtration capacity of the filter.
- Filter sand should be replaced every few years to maintain pollutant removal efficiency.

TARGETED POLLUTANTS

- High Impact
- Medium Impact
- Low or Unknown Impact

- Sediment
- Nutrients
- Heavy Metals
- Toxic Materials
- Oxygen Demanding Substances
- Oil & Grease
- Floatable Materials
- Bacteria & Viruses

IMPLEMENTATION REQUIREMENTS

- Capital Costs
- O&M Costs
- Maintenance
- Training

- High
- Medium
- Low

Materials Adopted From Salt Lake County Engineering Division Guidance Document

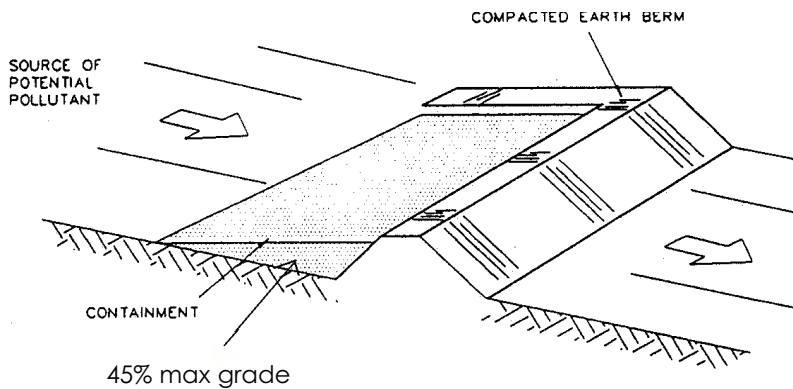

OBJECTIVES

- Housekeeping Practices
- Contain Waste
- Minimize Disturbed Areas
- Stabilize Disturbed Areas
- Protect Slopes/Channels
- Control Site Perimeter
- Control Internal Erosion



DESCRIPTION:

A temporary containment control constructed of compacted soil.

APPLICATION:

- Construct around waste and materials storage area.
- Construct around staging and maintenance areas.
- Construct around vehicle parking and servicing areas.

INSTALLATION/APPLICATION CRITERIA:

- Construct an earthen berm down hill of the area to be controlled. The berm should surround fueling facilities and maintenance areas on three sides to provide containment.
- Berm needs to be a minimum of 1 foot tall by 1 foot wide and be compacted by earth moving equipment.

LIMITATIONS:

- Not effective on steep slopes.
- Limits access to controlled area.
- Personnel need to quickly respond to spills with remedial actions.

MAINTENANCE:

- Observe daily for any non-stormwater discharge.
- Look for runoff bypassing ends of berms or undercutting berms.
- Repair or replace damaged areas of the berm and remove accumulated sediment.
- Recompact soil around berm as necessary to prevent piping.

TARGETED POLLUTANTS

- High Impact
- Medium Impact
- Low or Unknown Impact

- Sediment
- Nutrients
- Toxic Materials
- Oil & Grease
- Floatable Materials
- Other Construction Waste

IMPLEMENTATION REQUIREMENTS

- Capital Costs
- O&M Costs
- Maintenance
- Training

- High
- Medium
- Low

MATERIALS ADOPTED FROM SSALT LAKE COUNTY ENGINEERING DIVISION GUIDANCE DOCUMENT

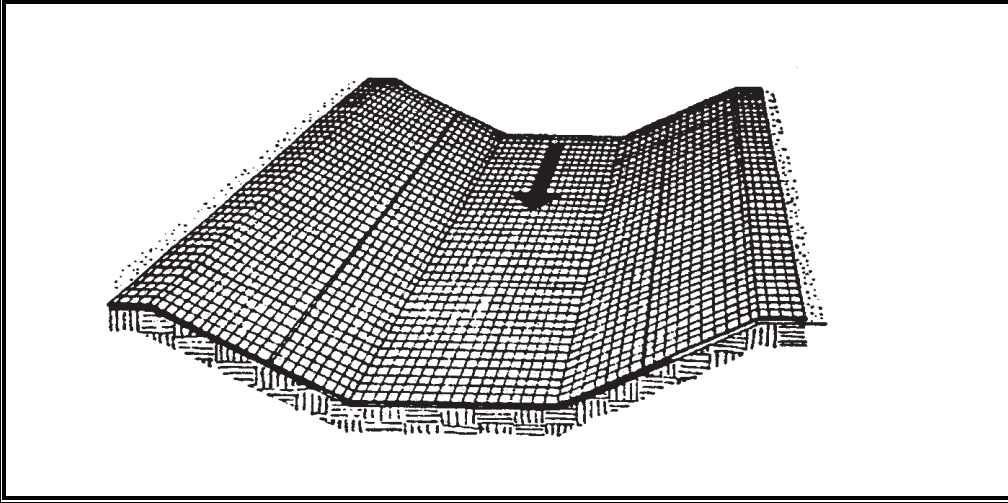

OBJECTIVES

- Housekeeping Practices
- Contain Waste
- Minimize Disturbed Areas
- Stabilize Disturbed Areas
- Protect Slopes/Channels
- Control Site Perimeter
- Control Internal Erosion

DESCRIPTION:

Erosion control blankets are used in place of mulch on areas of high velocity runoff and/or steep grade, to aid in controlling erosion on critical areas by protecting young vegetation.

APPLICATIONS:

- Where vegetation is likely to grow too slowly to provide adequate cover.
- In areas subject to high winds where mulch would not be effective.

INSTALLATION/APPLICATION CRITERIA:

- Install erosion control blankets parallel to the direction of the slope.
- In ditches, apply in direction of the flow.
- Place erosion control blankets loosely on soil - do not stretch.
- Ends of blankets should be buried no less than six inches deep.
- Staple the edges of the blanket at least every three feet.

LIMITATIONS:

- Not recommended in areas which are still under construction.

MAINTENANCE:

- Check for erosion and undermining periodically, particularly after rainstorms.
- Repair dislocations or failures immediately.
- If washouts occur, reinstall after repairing slope damage.
- Monitor until permanently stabilized.



TARGETED POLLUTANTS

- High Impact
- Medium Impact
- Low or Unknown Impact

- Sediment
- Nutrients
- Toxic Materials
- Oil & Grease
- Floatable Materials
- Other Waste

IMPLEMENTATION REQUIREMENTS

- Capital Costs
- O&M Costs
- Maintenance
- Training

- High
- Medium
- Low

Materials Adopted From Salt Lake County Engineering Guidance Document

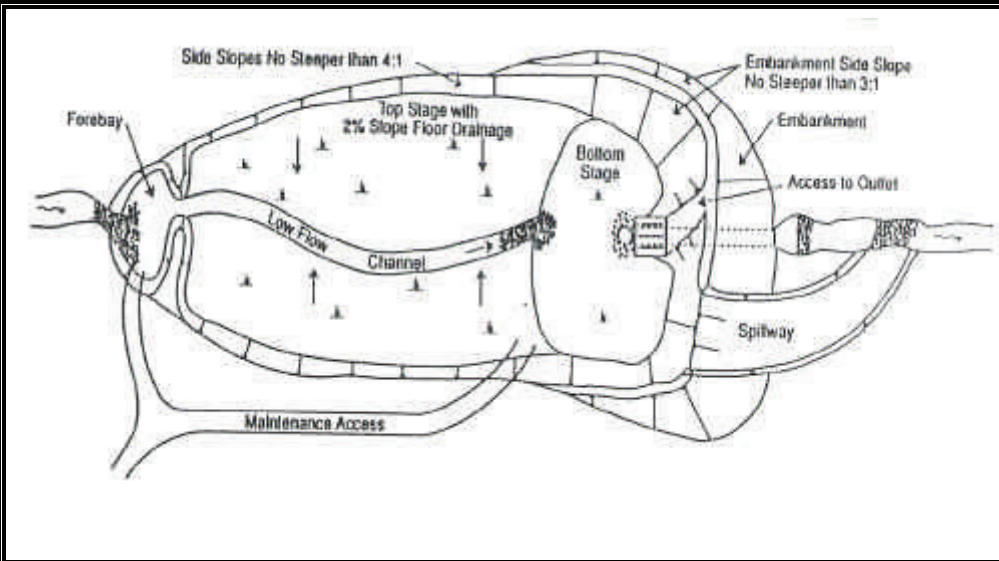

CONSIDERATIONS

- Soils
- Area Required
- Slope
- Water Availability
- Aesthetics
- Hydraulic Head
- Environmental Side Effects

DESCRIPTIONS:

Extended detention basins are dry between storms. During a storm the basin fills. A bottom outlet releases the stormwater slowly to provide time for sediments to settle.

APPLICATION:

- Objective is to remove only particulate pollutants.
- Use where lack of water prevents the use of wet ponds, wetlands or biofilters.
- Use where wet ponds or wetlands would cause unacceptable mosquito conditions.

INSTALLATION/APPLICATION CRITERIA:

- Basin volume is sized to capture a particular fraction of the runoff.
- Drawdown time of 24 to 40 hours.
- Shallow basin with large surface area performs better than deep basin with same volume.
- Place energy dissipators at the entrance to minimize bottom erosion and resuspension.
- Vegetate side slopes and bottom to the maximum extent practical.
- If side erosion is particularly severe, consider paving or soil stabilization.
- If floatables are a problem, protect outlet with trash rack or other device.
- Provide bypass or pass through capabilities for 100-year storm.

LIMITATIONS:

- May be less reliable than other treatment control BMPs. Inability to vegetate banks and bottom may result in erosion and resuspension.
- Limitation of the orifice diameter may preclude use in small watersheds.
- Requires differential elevation between inlet and outlet.

MAINTENANCE:

- Check outlet regularly for clogging.
- Check banks and bottom of basin for erosion and correct as necessary.
- Remove sediment when accumulation reaches 6-inches, or if resuspension is observed.



TARGETED POLLUTANTS

- High Impact
 - Medium Impact
 - Low or Unknown Impact

- Sediment
 - Nutrients
 - Heavy Metals
 - Toxic Materials
 - Oxygen Demanding Substances
 - Oil & Grease
 - Floatable Materials
 - Bacteria & Viruses

IMPLEMENTATION REQUIREMENTS

- Capital Costs
 - O&M Costs
 - Maintenance
 - Training

- High • Medium • Low

Materials Adopted From Salt Lake County Engineering Division Guidance Document

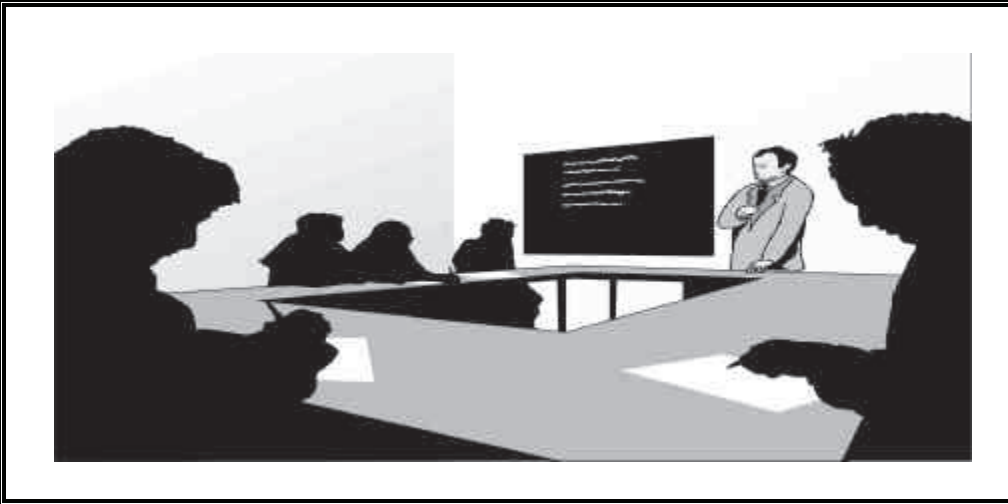

DESCRIPTION:

Employee training, like equipment maintenance, is a method by which to implement BMPs. Employee training should be used in conjunction with all other BMPs as part of the facility's SWPPP.

The specific employee training aspects of each of the source controls are highlighted in the individual information sheets. The focus of this information sheet is more general, and includes the overall objectives and approach for assuring employee training in stormwater pollution prevention. Accordingly, the organization of this information sheet differs somewhat from the other information sheets in this chapter.

OBJECTIVES:

Employee training should be based on four objectives:

- Promote a clear identification and understanding of the problem, including activities with the potential to pollute stormwater;
- Identify solutions (BMPs);
- Promote employee ownership of the problems and the solutions; and
- Integrate employee feedback into training and BMP implementation.

APPROACH:

- Integrate training regarding stormwater quality management with existing training programs that may be required for other regulations.
- Employee training is a vital component of many of the individual source control BMPs included in this manual.

PROGRAM ELEMENTS

- New Development
- Residential
- Commercial Activities
- Industrial Activities
- Municipal Facilities
- Illegal Discharges



TARGETED POLLUTANTS

- High Impact
 - Medium Impact
 - Low or Unknown Impact

- Sediment
- Nutrients
- Heavy Metals
- Toxic Materials
- Oxygen Demanding Substances
- Oil & Grease
- Floatable Materials
- Bacteria & Viruses

IMPLEMENTATION REQUIREMENTS

- Capital Costs
- O&M Costs
- Regulatory
 - Training
- Staffing
- Administrative

- High
- Medium
- Low

Materials Adopted From Salt Lake County Engineering Division Guidance Document

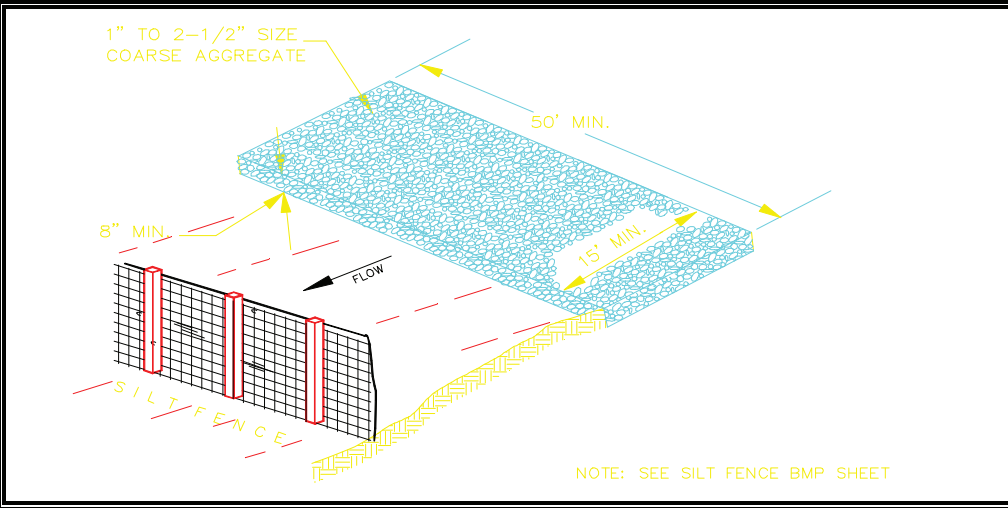

OBJECTIVES

- Housekeeping Practices
- Contain Waste
- Minimize Disturbed Areas
- Stabilize Disturbed Areas
- Protect Slopes/Channels
- Control Site Perimeter
- Control Internal Erosion



DESCRIPTION:

A stabilized pad of crushed stone for general washing of equipment and construction vehicles.

APPLICATION:

At any site where regular washing of vehicles and equipment will occur. May also be used as a filling point for water trucks limiting erosion caused by overflow or spillage of water.

INSTALLATION/APPLICATION CRITERIA:

- Clear and grub area and grade to provide maximum slope of 1%
- Compact subgrade and place filter fabric if desired (recommended for wash areas to remain in use for more than 3 months).
- Place coarse aggregate, 1 to 2-1/2 inches in size, to a minimum depth of 8-inches.
- Install silt fence downgradient (see silt fence BMP information sheet).

LIMITATIONS:

Cannot be utilized for washing equipment or vehicles that may cause contamination of runoff such as fertilizer equipment or concrete equipment. Solely used to control sediment in wash water.

MAINTENANCE:

- Inspect daily for loss of gravel or sediment buildup.
- Inspect adjacent area for sediment deposit and install additional controls as necessary.
- Repair area and replace gravel as required to maintain control in good working condition.
- Expand stabilized area as required to accommodate activities.
- Maintain silt fence as outlined in specific silt fence BMP information sheet.

TARGETED POLLUTANTS

- High Impact
- Medium Impact
- Low or Unknown Impact

- Sediment
- Nutrients
- Toxic Materials
- Oil & Grease
- Floatable Materials
- Other Waste

IMPLEMENTATION REQUIREMENTS

- Capital Costs
- O&M Costs
- Maintenance
- Training

- High
- Medium
- Low

MATERIALS ADOPTED FROM SALT LAKE COUNTY ENGINEERING DOCUMENT

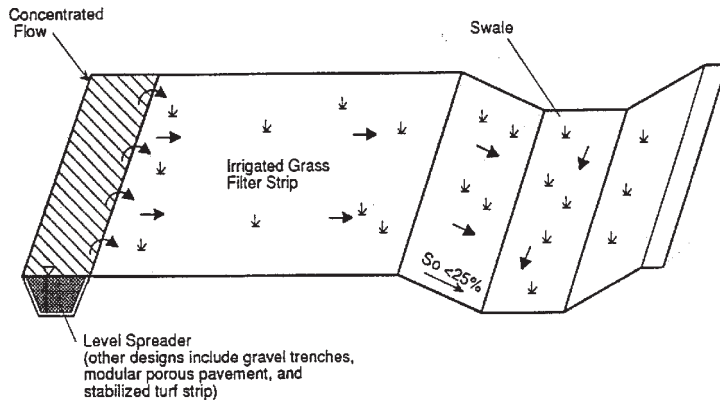

OBJECTIVES

- Housekeeping Practices
- Contain Waste
- Minimize Disturbed Areas
- Stabilize Disturbed Areas
- Protect Slopes/Channels
- Control Site Perimeter
- Control Internal Erosion

GENERAL DESCRIPTION:

Filter strips are 20-foot-wide strips of natural or planted vegetation around a construction site. They are designed to cause deposition of sediments within the vegetation layer.

APPLICATIONS:

- Suited for areas where the soils are well drained or moderately well drained.
- Areas where the bedrock and the water table are well below the surface.

INSTALLATION/APPLICATION CRITERIA:

- Make sure the vegetative cover is dense enough to protect underlying soil while causing sediment to settle.
- Filter strip must be approximately 20 feet wide to function well.
- The length should be approximately 50 to 75 feet. Where slopes become steeper the length of the strip must be increased.

LIMITATIONS:

- Only applicable in areas where vegetation is previously established or where sod is added.
- Vegetated filter strips will not function well on steep slopes, in hilly areas, or in highly paved areas.
- Sites with slopes of 15 percent or more may not be suitable for filtering storm water flows.

MAINTENANCE:

- Check for channels and repair.
- Provide rock aprons to aid in slowing flow if necessary.
- Maintain vegetation at optimal height and thickness.



TARGETED POLLUTANTS

- High Impact
- Medium Impact
- Low or Unknown Impact

- Sediment
- Nutrients
- Toxic Materials
- Oil & Grease
- Floatable Materials
- Other Waste

IMPLEMENTATION REQUIREMENTS

- Capital Costs
- O&M Costs
- Maintenance
- Training

- High
- Medium
- Low

Materials Adopted From Salt Lake County Engineering Division Guidance Document



CONSIDERATIONS

- Soils
- Area Required
- Slope
- Water Availability
- Aesthetics
- Hydraulic Head
- Environmental Side Effects



DESCRIPTION:

Floatable skimmers are devices used to retain floating debris and oil in detention areas. The floating debris and oil eventually sinks to the bottom of the detention area and becomes part of the sediments or is removed from the surface through regular maintenance.

The effect of floatable skimmers on water quality will depend upon the amount and type of floating material transported by runoff. Typically, a well designed floatable skimmer can trap virtually all floating debris that reaches it. In an area with large amounts of floating leaves, trash or oil, this can provide significant water quality benefits.

APPLICATION:

Applicable in areas where detention basins are used.

INSTALLATION/APPLICATION CRITERIA:

- For structures with a weir outlet, a baffle weir should be used. It should be located far enough upstream of the weir outlet to prevent high velocity flow through it.
- Generally, it is best to keep velocities at the skimmer less than 1 foot per second.

LIMITATIONS:

Tend to clog with debris.

MAINTENANCE:

Maintenance is very important for the proper function of a floatable skimmer. After runoff events that transport large amounts of floating debris and trash, the skimmer can become clogged with a mat of trapped material. This debris must be removed promptly to maintain the capacity of the structure for future storms.

TARGETED POLLUTANTS

- High Impact
- Medium Impact
- Low or Unknown Impact

- Sediment
- Nutrients
- Heavy Metals
- Toxic Materials
- Oxygen Demanding Substances
- Oil & Grease
- Floatable Materials
- Bacteria & Viruses

IMPLEMENTATION REQUIREMENTS

- Capital Costs
- O&M Costs
- Maintenance
- Training

- High
- Medium
- Low

Materials Adopted from Salt Lake County Engineering Division Guidance Document

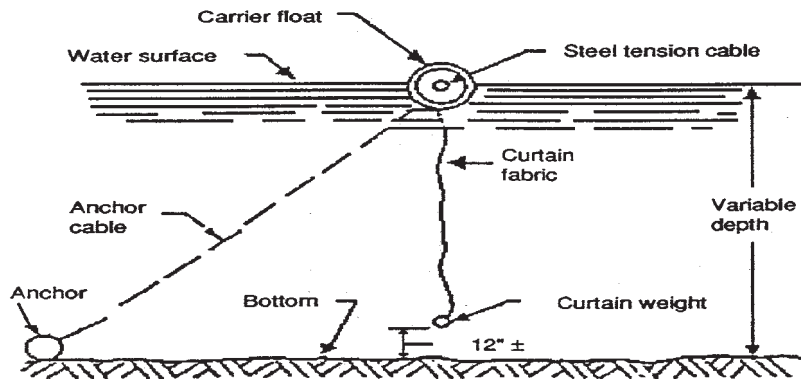

DESCRIPTION:

A flotation silt curtain is a silt barrier for use within a lake or pond. The flotation silt curtain consists of a filter fabric curtain weighted at the bottom and attached to a flotation device at the top. This structure is used to isolate an active construction area within a lake or pond to prevent silt-laden water from migrating out of the construction zone.

APPLICATIONS:

Where construction is conducted within a lake or pond area.

INSTALLATION/APPLICATION CRITERIA:

- The curtain should be constructed of a nylon fabric with a minimum tensile strength of 300 pounds per inch of fabric.
- The top of the curtain should have a flotation carrier consisting of a floating plastic tube (6-inch minimum diameter) filled with marine quality polyethylene foam. The flotation carrier should also have a 5/16" diameter coated steel cable in it to carry loads imposed upon the curtain.
- The bottom edge should be weighted by cable or chain with a minimum weight of 1.1 pounds per foot.
- One 24-pound anchor should be used per 100 feet of curtain.
- Where the curtain is made up of sections, the sections should be joined so that silt cannot permeate through the connection.

LIMITATIONS:

Not recommended in very shallow water bodies.

MAINTENANCE:

The silt curtain should be maintained until the construction area is stabilized and turbidity is reduced to acceptable levels.

OBJECTIVES

- Housekeeping Practices
- Contain Waste
- Minimize Disturbed Areas
- Stabilize Disturbed Areas
- Protect Slopes/Channels
- Control Site Perimeter
- Control Internal Erosion



TARGETED POLLUTANTS

- High Impact
- Medium Impact
- Low or Unknown Impact

- Sediment
- Nutrients
- Toxic Materials
- Oil & Grease
- Floatable Materials
- Other Waste

IMPLEMENTATION REQUIREMENTS

- Capital Costs
- O&M Costs
- Maintenance
- Training

- High
- Medium
- Low

Materials Adopted From Salt Lake County Engineering Division Guidance Document

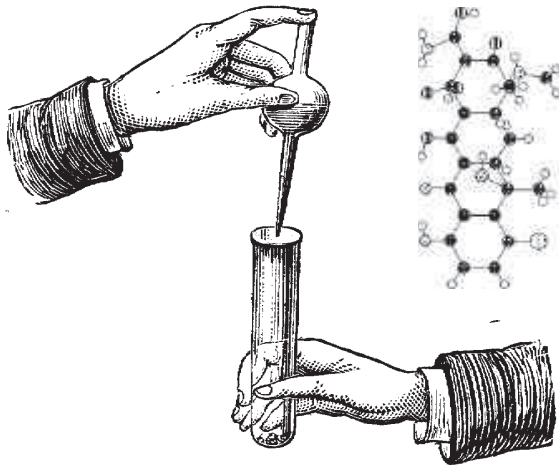

CONSIDERATIONS

- Soils
- Area Required
- Slope
- Water Availability
- Aesthetics
- Hydraulic Head
- Environmental Side Effects



DESCRIPTION:

Gelling agents are materials that interact with liquids either physically or chemically (i.e., thickening or polymerization). Some of the typical gelling agents are polyelectrolytes, polyacrylamide, butylstyrene copolymers, polyacrylonitrile, polyethylene oxide, and a gelling agent referred to as the universal gelling agent which is a combination of these synthetics.

APPLICATION:

Gelling agents are useful for facilities with significant amounts of liquid materials stored onsite.

INSTALLATION/APPLICATION CRITERIA:

- The use of gels simply involves the addition of the gel to the area of the spill, mixing well, and allowing the mass to congeal.
- Personnel need to know the properties of the spilled material so that they can choose the correct gel.
- To prevent the movement of spilled materials, gelling agents must be applied immediately after the spill.
- Ultimately, the congealed mass will need to be cleaned up by manual or mechanical methods and disposed of properly.

MAINTENANCE:

No information available.

LIMITATIONS:

- May require knowledge of the spilled materials to select correct gelling agents.
- May be difficult to clean up
- May create disposal problems and increase disposal costs by creating a solid waste and potentially a hazardous waste.
- Gels cannot be used to clean up spills on surface water unless authorized by the U.S. Coast Guard or EPA Regional Response Team.

TARGETED POLLUTANTS

- High Impact
- Medium Impact
- Low or Unknown Impact
- Sediment
- Nutrients
- Heavy Metals
- Toxic Materials
- Oxygen Demanding Substances
- Oil & Grease
- Floatable Materials
- Bacteria & Viruses

IMPLEMENTATION REQUIREMENTS

- Capital Costs
- O&M Costs
- Maintenance
- Training

- High
- Medium
- Low

Materials Adopted From Salt Lake County Engineering Division Guidance Document

FLOW RATES VARY ACCORDING TO MANUFACTURER

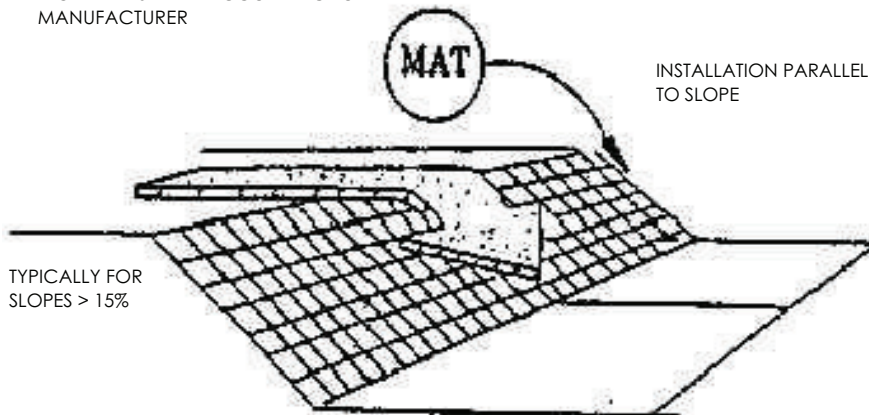

OBJECTIVES

- Housekeeping Practices
- Contain Waste
- Minimize Disturbed Areas
- Stabilize Disturbed Areas
- Protect Slopes/Channels
- Control Site Perimeter
- Control Internal Erosion

DESCRIPTION:

Mattings made of natural or synthetic material which are used to temporarily or permanently stabilize soil.

APPLICATION:

- Typically suited for post-construction site stabilization, but may be used for temporary stabilization of highly erosive soils.
- Channels and streams.
- Steep slopes.

INSTALLATION/APPLICATION CRITERIA:

- Mattings may be applied to disturbed soils and where existing vegetation has been removed.
- The following organic matting materials provide temporary protection until permanent vegetation is established, or when seasonal circumstances dictate the need for temporary stabilization until weather or construction delays are resolved: Jute mattings and straw mattings.
- The following synthetic mattings may be used for either temporary or post-construction stabilization, both with and without vegetation: excelsior matting, glass fiber matting, mulch matting.
- Staples are needed to anchor the matting.

LIMITATIONS:

- Mattings are more costly than other BMP practices, limiting their use to areas where other BMPs are ineffective (e.g., channels, steep slopes).
- May delay seed germination, due to reduction in soil temperature.
- Installation requires experienced contractor to ensure soil stabilization and erosion protection.

MAINTENANCE:

- Inspect monthly and after significant rainfall.
- Re-anchor loosened matting and replace missing matting and staples as required.



TARGETED POLLUTANTS

- High Impact
- Medium Impact
- Low or Unknown Impact

- Sediment
- Nutrients
- Toxic Materials
- Oil & Grease
- Floatable Materials
- Other Waste

IMPLEMENTATION REQUIREMENTS

- Capital Costs
- O&M Costs
- Maintenance
- Training

- High
- Medium
- Low

Materials Adopted From Salt Lake County Engineering Division Guidance Document



OBJECTIVES

- Housekeeping Practices
- Contain Waste
- Minimize Disturbed Areas
- Stabilize Disturbed Areas
- Protect Slopes/Channels
- Control Site Perimeter
- Control Internal Erosion



DESCRIPTION:

A combination of wood fiber mulch, processed grass, or hay or straw mulch and a tacking agent. It is made into a slurry, then applied to bare slopes or other bare areas to provide temporary stabilization.

APPLICATIONS:

- Small roadside slopes.
- Large, relatively flat areas.

INSTALLATION/APPLICATION CRITERIA:

- Legume seeds should be pellet inoculated with the appropriate bacteria.
- The seed should not remain in the hydromulcher tank for more than 30 minutes.
- Wood fiber may be dyed to aid in uniform application.
- Slurry should be uniformly applied until an adequate coverage is achieved.
- The applicator should not be directed at one location for a long period of time; erosion will occur.

LIMITATIONS:

- Will lose effectiveness after 1 year.
- Can use only on physically stable slopes (at natural angle of repose, or less).

MAINTENANCE:

- Periodically inspect for damage caused by wind, water, or human disturbance.
- Promptly repair damaged areas.

TARGETED POLLUTANTS

- High Impact
 - Medium Impact
 - Low or Unknown Impact

- Sediment
- Nutrients
- Toxic Materials
- Oil & Grease
- Floatable Materials
- Other Waste

IMPLEMENTATION REQUIREMENTS

- Capital Costs
- O&M Costs
- Maintenance
- Training

- High
- Medium
- Low

Materials Adopted From Salt Lake County Engineering Division Guidance Document



DESCRIPTION:

Promote efficient and safe housekeeping practices (storage, use, and cleanup) when handling potentially harmful materials such as fertilizers, pesticides, cleaning solutions, paint products, automotive products, and swimming pool chemicals.

APPROACH:

- Pattern a new program after the many established programs from municipalities around the country. Integrate this best management practice as much as possible with existing programs at your municipality.
- This BMP has two key audiences: municipal employees and the general public.
- For the general public, municipalities should establish a public education program that provides information on such items as storm water pollution and beneficial effects of proper disposal on water quality; reading product labels; safer alternative products; safe storage, handling, and disposal of hazardous products; list of local agencies; and emergency phone numbers. The programs listed below have provided this information through brochures or booklets that are available at a variety of locations including municipal offices, household hazardous waste collection events or facilities, and public information fairs.

Municipal facilities should develop controls on the application of pesticides, herbicides, and fertilizers in public right-of-ways and at municipal facilities.

Controls may include:

- List of approved pesticides and selected uses.
- Product and application information for users.
- Equipment use and maintenance procedures.
- Record keeping and public notice procedures.

LIMITATIONS:

There are no major limitations to this best management practice.

PROGRAM ELEMENTS

- New Development
- Residential
- Commercial Activities
- Industrial Activities
- Municipal Facilities
- Illegal Discharges



TARGETED POLLUTANTS

- High Impact
- Medium Impact
- Low or Unknown Impact

- Sediment
- Nutrients
- Heavy Metals
- Toxic Materials
- Oxygen Demanding Substances
- Oil & Grease
- Floatable Materials
- Bacteria & Viruses

IMPLEMENTATION REQUIREMENTS

- Capital Costs
- O&M Costs
- Regulatory
- Training
- Staffing
- Administrative

- High
- Medium
- Low

Materials Adopted From Salt Lake County Engineering Division Guidance Document



OBJECTIVES

- Housekeeping Practices
- Contain Waste
- Minimize Disturbed Areas
- Stabilize Disturbed Areas
- Protect Slopes/Channels
- Control Site Perimeter
- Control Internal Erosion

DESCRIPTION:

Prevent or reduce the discharge of pollutants to stormwater from hazardous waste through proper material use, waste disposal, and training of employees and subcontractors.

APPLICATION:

Many of the chemicals used on-site can be hazardous materials which become hazardous waste upon disposal. These wastes may include:

- Paints and Solvents; petroleum products such as oils, fuels, and grease; herbicides and pesticides; Acids for cleaning masonry; and concrete curing compounds.

In addition, sites with existing structures may contain wastes which must be disposed of in accordance with Federal, State, and local regulations, including:

- Sandblasting grit mixed with lead, cadmium, or chromium-based paints; Asbestos; and PCB's.

INSTALLATION/APPLICATION CRITERIA:

The following steps will help reduce storm water pollution from hazardous wastes:

- Use all of the product before disposing of the container.
- Do not remove the original product label, it contains important safety and disposal information.
- Do not over-apply herbicides and pesticides. Prepare only the amount needed. Follow the recommended usage instructions. Over-application is expensive and environmentally harmful. Apply surface dressings in several smaller applications, as opposed to one large application, to allow time for infiltration and to avoid excess material being carried off-site by runoff. Do not apply these chemicals just before it rains. People applying pesticides must be certified in accordance with Federal and State regulations.

LIMITATIONS:

Hazardous waste that cannot be reused or recycled must be disposed of by a licensed hazardous waste hauler.

MAINTENANCE:

- Inspect hazardous waste receptacles and area regularly.
- Arrange for regular hazardous waste collection.



TARGETED POLLUTANTS

- High Impact
- Medium Impact
- Low or Unknown Impact

- Sediment
- Nutrients
- Toxic Materials
- Oil & Grease
- Floatable Materials
- Other Waste

IMPLEMENTATION REQUIREMENTS

- Capital Costs
- O&M Costs
- Maintenance
- Training

- High
- Medium
- Low

Materials Adopted From Salt Lake County Engineering Division Guidance Document

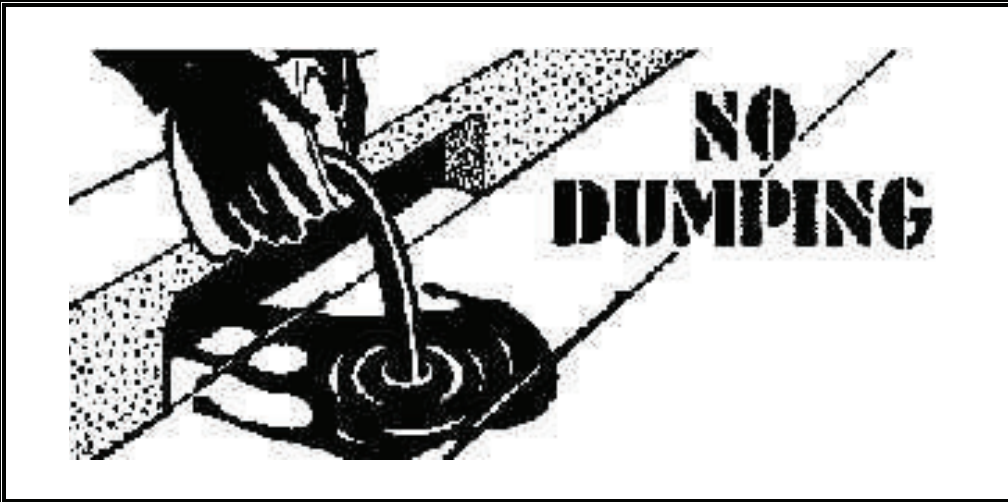

DESCRIPTION:

Implement measures to detect, correct, and enforce against illegal dumping of pollutants on streets, into the storm drain system, and into creeks. Substances illegally dumped on streets, into the storm drain system, and into creeks includes paints, used oil and other automotive fluids, construction debris, chemicals, fresh concrete, leaves, grass clippings, and pet wastes. All of these wastes can cause storm water and receiving water quality problems as well as clog the storm drain system.

APPROACH:

One of the keys to success is increasing the general public's awareness of the problem and to at least identify the incident, if not correct it. There are a number of ways of accomplishing this:

- Train municipal staff from all departments to recognize and report incidents.
- Deputize municipal staff who may come into contact with illegal dumping with the authority to write illegal dumping tickets for offenders caught in the act.
- Educate the public.
- Provide the public with a mechanism for reporting such as a hot line.

Establish system for tracking incidents which will identify:

- Illegal dumping "hot spots",
- Types and quantities (in some cases) of wastes,
- Patterns in time of occurrence (time of day/night, month, or year),
- Mode of dumping (abandoned containers, "midnight dumping" from moving vehicles, direct dumping of materials, accident/spills), and
- Responsible parties.

A tracking system also helps manage the program by indicating trends, and identifying who, what, when, and where efforts should be concentrated.

LIMITATIONS

The elimination of illegal dumping is dependent on the availability, convenience, and cost of alternative means of disposal.

PROGRAM ELEMENTS

- New Development
- Residential
- Commercial Activities
- Industrial Activities
- Municipal Facilities
- Illegal Discharges



TARGETED POLLUTANTS

- High Impact
- Medium Impact
- Low or Unknown Impact

- Sediment
- Nutrients
- Heavy Metals
- Toxic Materials
- Oxygen Demanding Substances
- Oil & Grease
- Floatable Materials
- Bacteria & Viruses

IMPLEMENTATION REQUIREMENTS

- Capital Costs
- O&M Costs
- Regulatory
- Training
- Staffing
- Administrative

- High
- Medium
- Low

Materials Adopted From Salt Lake County Engineering Division Guidance Document

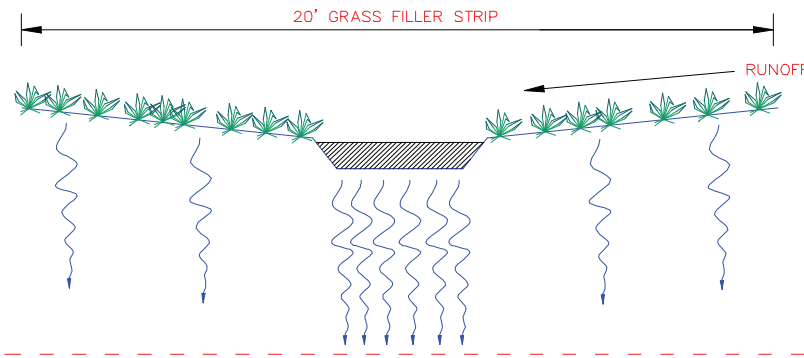

CONSIDERATIONS

- Soils
- Area Required
- Slope
- Water Availability
- Aesthetics
- Hydraulic Head
- Environmental Side Effects



DESCRIPTION:

A family of systems in which the majority of the runoff from small storms is infiltrated into the ground rather than discharged to a surface water body. Infiltration systems include: ponds, vaults, trenches, dry wells, porous pavement, and concrete grids.

APPLICATION:

- Need to achieve high level of particulate and dissolved pollutant removal.
- Suitable site soils and geologic conditions; low potential for long-term erosion in the watershed.
- Multiple management objectives (e.g., ground water recharge or runoff volume control).

INSTALLATION/APPLICATION CRITERIA:

- Volume sized to capture a particular fraction of annual runoff.
- Pretreatment in fine soils.
- Emergency overflow or bypass for larger storms.
- Observation well in trenches.

LIMITATIONS:

- Loss of infiltrative capacity and high maintenance cost in fine soils.
- Low removal of dissolved pollutants in very coarse soils.
- Not suitable on fill sites or steep slopes.
- Risk of ground water contamination in very coarse soils, may require ground water monitoring.
- Should not use until upstream drainage area is stabilized.
- Infiltration facilities could fall under regulations regarding waste disposal to land.

MAINTENANCE:

- Remove sediment at frequency appropriate to avoid excessive concentrations of pollutants and loss of infiltrative capacity.
- Frequent cleaning of porous pavements.
- Maintenance is difficult and costly for underground trenches.

TARGETED POLLUTANTS

- High Impact
- Medium Impact
- Low or Unknown Impact

- Sediment
- Nutrients
- Heavy Metals
- Toxic Materials
- Oxygen Demanding Substances
- Oil & Grease
- Floatable Materials
- Bacteria & Viruses

IMPLEMENTATION REQUIREMENTS

- Capital Costs
- O&M Costs
- Maintenance
- Training

- High
- Medium
- Low

Materials Adopted From Salt Lake County Engineering Division Guidance Document

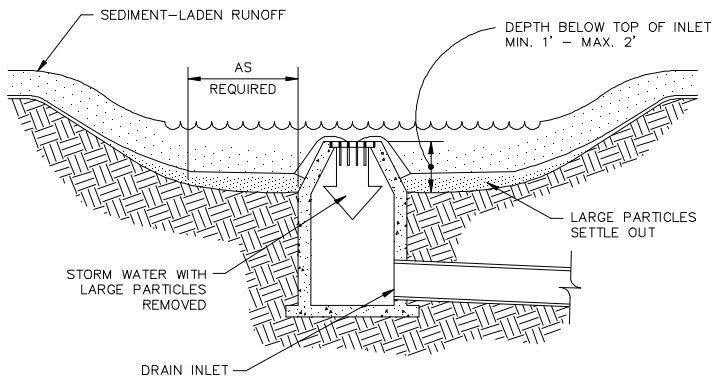

OBJECTIVES

- Housekeeping Practices
- Contain Waste
- Minimize Disturbed Areas
- Stabilize Disturbed Areas
- Protect Slopes/Channels
- Control Site Perimeter
- Control Internal Erosion



DESCRIPTION:

An area excavated around a storm drain inlet to impound water below the inlet.

APPLICATION:

Construct at storm drainage inlets located downgradient of areas to be disturbed by construction (for inlets in paved areas see other information sheets for inlet protection).

INSTALLATION/APPLICATION CRITERIA:

- Provide upgradient sediment controls, such as silt fence during construction of inlet.
- When construction of inlet is complete, excavate adjacent area 1 to 2 feet lower than the grate elevation. Size of excavated area should be based on soil type and contributing acreage.

LIMITATIONS:

- Recommended maximum contributing drainage area of one acre.
- Limited to inlets located in open unpaved areas.
- Requires flat area adjacent to inlet.

MAINTENANCE:

- Inspect inlet protection following storm event and at a minimum of once monthly.
- Remove accumulated sediment when it reaches one half of the excavated sump below the grate.
- Repair side slopes as required.

TARGETED POLLUTANTS

- High Impact
- Medium Impact
- Low or Unknown Impact

- Sediment
- Nutrients
- Toxic Materials
- Oil & Grease
- Floatable Materials
- Other Waste

IMPLEMENTATION REQUIREMENTS

- Capital Costs
- O&M Costs
- Maintenance
- Training

- High
- Medium
- Low

Materials Adopted From Salt Lake County Engineering Division Guidance Document

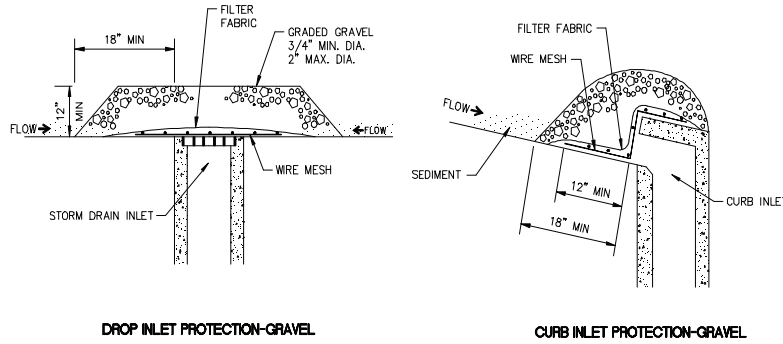

OBJECTIVES

- Housekeeping Practices
- Contain Waste
- Minimize Disturbed Areas
- Stabilize Disturbed Areas
- Protect Slopes/Channels
- Control Site Perimeter
- Control Internal Erosion

DESCRIPTION:

Placement of gravel filter over inlet to storm drain to filter storm water runoff.

APPLICATION:

Construct at inlets in paved or unpaved areas where upgradient area is to be disturbed by construction activities.

INSTALLATION/APPLICATION CRITERIA:

- Place wire mesh (with ½ inch openings) over the inlet grate extending one foot past the grate in all directions.
- Place filter fabric over the mesh. Filter fabric should be selected based on soil type.
- Place graded gravel, to a minimum depth of 12-inches, over the filter fabric and extending 18-inches past the grate in all directions.

LIMITATIONS:

- Recommended for maximum drainage area of one acre.
- Excess flows may bypass the inlet requiring down gradient controls.
- Ponding will occur at inlet.

MAINTENANCE:

- Inspect inlet protection after every large storm event and at a minimum of once monthly.
- Remove sediment accumulated when it reaches 4-inches in depth.
- Replace filter fabric and clean or replace gravel if clogging is apparent.



TARGETED POLLUTANTS

- High Impact
- Medium Impact
- Low or Unknown Impact

- Sediment
- Nutrients
- Toxic Materials
- Oil & Grease
- Floatable Materials
- Other Waste

IMPLEMENTATION REQUIREMENTS

- Capital Costs
- O&M Costs
- Maintenance
- Training

- High
- Medium
- Low

Materials Adopted From Salt Lake County Engineering Division Guidance Document

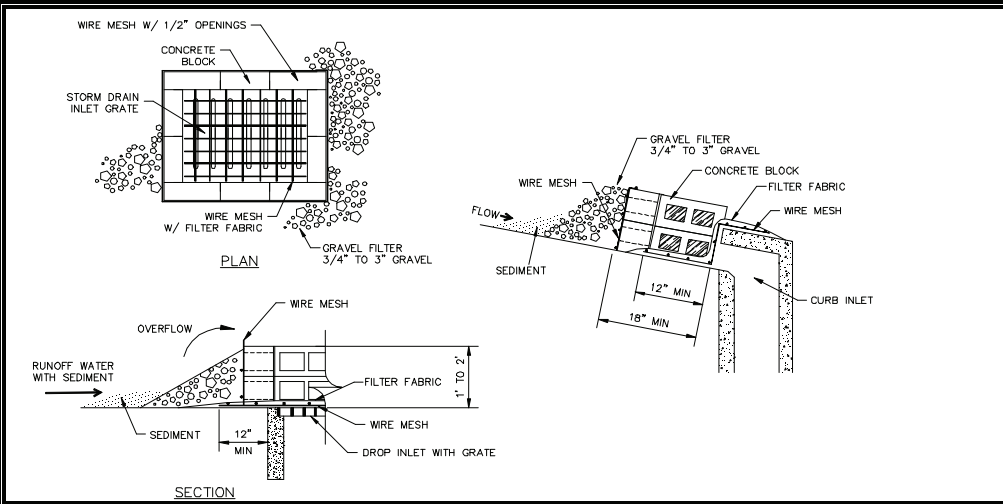

OBJECTIVES

- Housekeeping Practices
- Contain Waste
- Minimize Disturbed Areas
- Stabilize Disturbed Areas
- Protect Slopes/Channels
- Control Site Perimeter
- Control Internal Erosion

DESCRIPTION:

Concrete block and gravel filter placed over inlet to storm drain system.

APPLICATION:

Construct at inlets in paved or unpaved areas where upgradient area is to be disturbed by construction activities.

INSTALLATION/APPLICATION CRITERIA:

- Place wire mesh (with 1/2 inch openings) over the inlet grate extending one foot past the grate in all directions.
- Place concrete blocks around the inlet with openings facing outward. Stack blocks to minimum height of 12-inches and maximum height of 24-inches.
- Place wire mesh around outside of blocks.
- Place gravel (3/4" to 3") around blocks.

LIMITATIONS:

- Recommended for maximum drainage area of one acre.
- Excess flows may bypass the inlet requiring down gradient controls.
- Ponding will occur at inlet.

MAINTENANCE:

- Inspect inlet protection after every large storm event and at a minimum of once monthly.
- Remove sediment accumulated when it reaches 4-inches in depth.
- Replace filter fabric and clean or replace gravel if clogging is apparent.



TARGETED POLLUTANTS

- High Impact
 - Medium Impact
 - Low or Unknown Impact
- Sediment
 - Nutrients
 - Toxic Materials
 - Oil & Grease
- Floatable Materials
 - Other Waste

IMPLEMENTATION REQUIREMENTS

- Capital Costs
- O&M Costs
- Maintenance
- Training

- High
- Medium
- Low

Materials Adopted From Salt Lake County Engineering Division Guidance Document

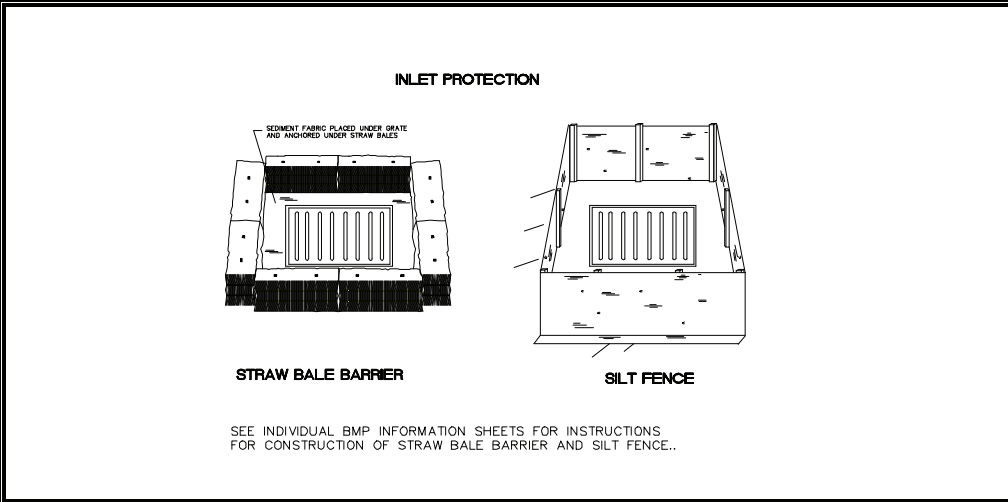

OBJECTIVES

- Housekeeping Practices
- Contain Waste
- Minimize Disturbed Areas
- Stabilize Disturbed Areas
- Protect Slopes/Channels
- Control Site Perimeter
- Control Internal Erosion

DESCRIPTION:

Sediment barrier erected around storm drain inlet.

APPLICATION:

Construct at storm drainage inlets located downgradient of areas to be disturbed by construction (for inlets in paved areas see other information sheets for inlet protection).

INSTALLATION/APPLICATION CRITERIA:

- Provide upgradient sediment controls, such as silt fence during construction of inlet.
- When construction of inlet is complete, erect straw bale barrier or silt fence surrounding perimeter of inlet. Follow instructions and guidelines on individual BMP information sheets for straw bale barrier and silt fence construction.

LIMITATIONS:

- Recommended maximum contributing drainage area of one acre.
- Limited to inlets located in open unpaved areas.
- Requires shallow slopes adjacent to inlet.

MAINTENANCE:

- Inspect inlet protection following storm event and at a minimum of once monthly.
- Remove accumulated sediment when it reaches 4-inches in depth.
- Repair or realign barrier/fence as needed.
- Look for bypassing or undercutting and recompact soil around barrier/fence as required.



TARGETED POLLUTANTS

- High Impact
- Medium Impact
- Low or Unknown Impact

- Sediment
- Nutrients
- Toxic Materials
- Oil & Grease
- Floatable Materials
- Other Waste

IMPLEMENTATION REQUIREMENTS

- Capital Costs
- O&M Costs
- Maintenance
- Training

- High
- Medium
- Low

Materials Adopted From Salt Lake County Engineering Division Guidance Document



DESCRIPTION:

Litter control involves the removal of litter from streets and other surfaces before runoff or wind moves these materials to surface waters. This practice will prevent litter from becoming pollution as well as improving the aesthetics of the area.

APPROACH:

There are two categories of litter control programs: source reduction and removal programs.

Source reduction:

- Litter containers should be conveniently placed and emptied frequently to prevent overflow.
- Recycling programs should be promoted.
- Public education programs should be developed since litter control programs depend upon public support.

Litter removal programs:

- Litter control program include refuse and leaf collection, street cleaning, and catch basin cleaning.
- Educational programs that explain the environmental benefit of leaf collection to water quality are helpful.
- Municipal leaf collection is usually accomplished with street sweepers (see Street Cleaning BMP) or mechanical lawn sweepers.

LIMITATIONS:

No limitations.

PROGRAM ELEMENTS

- New Development
- Residential
- Commercial Activities
- Industrial Activities
- Municipal Facilities
- Illegal Discharges



TARGETED POLLUTANTS

- High Impact
- Medium Impact
- Low or Unknown Impact

- Sediment
- Nutrients
- Heavy Metals
- Toxic Materials
- Oxygen Demanding Substances
- Oil & Grease
- Floatable Materials
- Bacteria & Viruses

IMPLEMENTATION REQUIREMENTS

- Capital Costs
- O&M Costs
- Regulatory
- Training
- Staffing
- Administrative

- High
- Medium
- Low

Materials Adopted From Salt Lake County Engineering Division Guidance Document

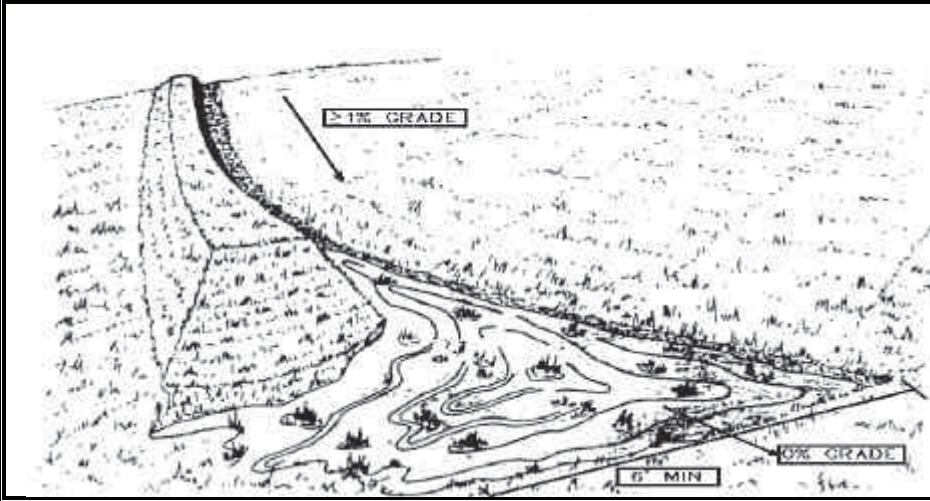

DESCRIPTION:

Level spreaders are devices used at stormwater outlets to spread out collected stormwater flows into sheetflow (runoff that flows over ground surface in a thin, even layer). Typically, a level spreader consists of a depression in the soil surface that spreads the flow onto a flat area across a gentle slope. Level spreaders then release the stormwater flow onto level areas stabilized by vegetation to reduce speed and increase infiltration.

APPLICATION:

Level spreaders are most often used as an outlet for temporary or permanent stormwater conveyances or dikes. Runoff that contains high sediment loads should be treated in a sediment trapping device prior to release into a level spreader.

INSTALLATION/APPLICATION CRITERIA:

- The length of the spreader depends upon the amount of water that flows through the conveyance.
- Larger volumes of water need more space to even out.
- Level spreaders are generally used with filter strips (see Filter Strips BMP).
- The depressions are seeded with vegetation (see Permanent & Temporary Seeding BMP).
- Level spreaders should be constructed on natural soils and not on fill material.
- The entrance to the spreader should be level so that the flow can spread out evenly.

LIMITATIONS:

- Can easily develop "short circuiting" (concentration of flows into small streams instead of sheetflow over the spreader) because of erosion or other disturbance.
- Cannot handle large quantities of sediment-laden stormwater.

MAINTENANCE:

- The spreader should be inspected after every storm event to check for damage.
- If ponding or erosion channels develop, the spreader should be regraded.
- Dense vegetation should be maintained and damaged areas reseeded as needed.

CONSIDERATIONS

- Soils
- Area Required
- Slope
- Water Availability
- Aesthetics
- Hydraulic Head
- Environmental Side Effects



TARGETED POLLUTANTS

- High Impact
- Medium Impact
- Low or Unknown Impact
- Sediment
- Nutrients
- Heavy Metals
- Toxic Materials
- Oxygen Demanding Substances
- Oil & Grease
- Floatable Materials
- Bacteria & Viruses

IMPLEMENTATION REQUIREMENTS

- Capital Costs
- O&M Costs
- Maintenance
- Training

- High
- Medium
- Low

Materials Adopted From Salt Lake County Engineering Division Guidance Document

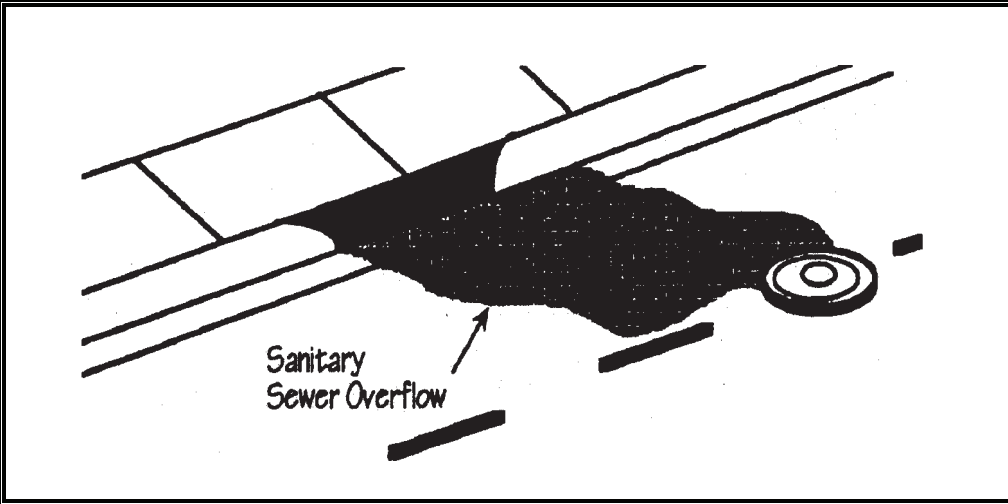

PROGRAM ELEMENTS

- New Development
- Residential
- Commercial Activities
- Industrial Activities
- Municipal Facilities
- Illegal Discharges



DESCRIPTION:

Implement control procedures for identifying, repairing, and remediating sewer blockages, infiltration, inflow, and wet weather overflows from sanitary sewers into the storm drain conveyance system. Procedures include field screening, follow-up testing, and complaint investigation.

APPROACH:

- Identify dry weather infiltration and inflow first. Wet weather overflow connections are very difficult to locate.
- Locate wet weather overflows and leaking sanitary sewers using conventional source identification techniques.
- Coordinate with ongoing infiltration and inflow (I & I) program to locate sources of exfiltration during I & I inspections.
- Design, site, operate, and maintain on-site sewage disposal systems to prevent nutrient/pathogen loadings to surface waters and to reduce loadings to groundwater.

Leaking sanitary sewer detection techniques include:

- Field screening program (including field analytical testing),
- Fluorometric dye testing,
- Zinc chloride smoke testing,
- Television camera inspection,
- Nessler Reagent test kits for ammonia detection,
- Citizens' hotline reporting of wet weather sanitary overflows.

LIMITATIONS:

- Private property access rights needed to perform field screening/testing along storm drain right-of-ways.
- Requirements of municipal ordinance authority for suspected source verification testing necessary for guaranteed rights of entry.

TARGETED POLLUTANTS

- High Impact
- Medium Impact
- Low or Unknown Impact

- Sediment
- Nutrients
- Heavy Metals
- Toxic Materials
- Oxygen Demanding Substances
- Oil & Grease
- Floatable Materials
- Bacteria & Viruses

IMPLEMENTATION REQUIREMENTS

- Capital Costs
- O&M Costs
- Regulatory
- Training
- Staffing
- Administrative

- High
- Medium
- Low

Materials Adopted From Salt Lake County Engineering Division Guidance Document

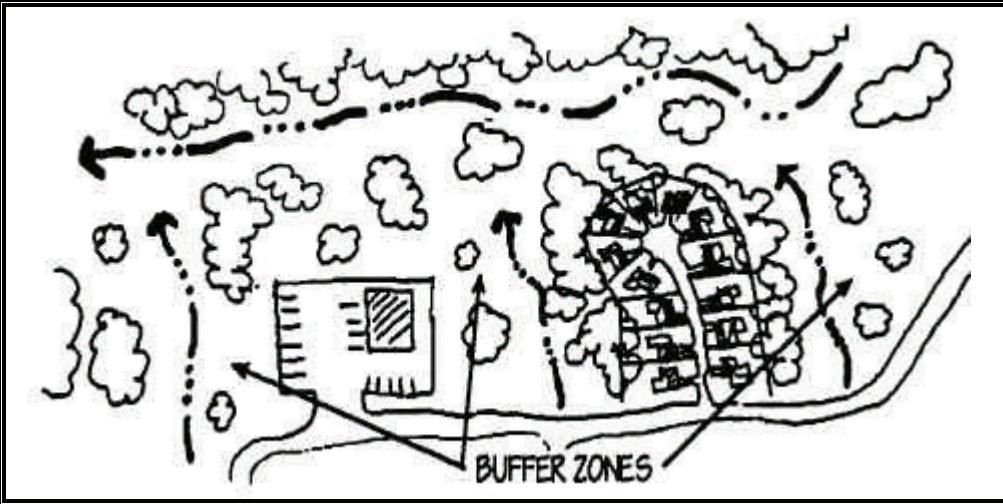

DESCRIPTION:

This BMP represents an important opportunity to reduce pollutants in stormwater runoff by using a comprehensive planning process to integrate water quality concerns into the development and redevelopment process. It is applicable to all types of land use and represents one of the most effective pollution prevention practices.

APPROACH:

The land use planning process need not be complex. A basic schematic model involves:

- Phase 1 - Goals: Determine clear-cut water quality goals.
- Phase 2 - Study: Identify planning area, gather pertinent data, and write a description of the planning area and its associated problems.
- Phase 3 - Analysis and Synthesis: Determine and prioritize the water quality needs as they relate to land use.
- Phase 4 - Recommendations: Future courses of action are developed to address the identified problems and needs determined previously.
- Phase 5 - Adoption: The recommendations are presented to a political body for acceptance and implementation.
- Phase 6 - Implementation: Recommendations adopted by the political body are implemented by the locality.

LIMITATIONS:

- Land use planning/management frequently addresses sensitive public issues. Restrictions on certain land uses for the purpose of mitigating stormwater pollution may be politically unacceptable.
- The use of land use controls and planning for water quality improvements may be limited by the lack of staff to enforce various aspects of local zoning and building codes.
- The planning process addresses many public needs and legal requirements which often are in conflict with one another. It is difficult but extremely important to integrate and balance these sometimes competing programs.

PROGRAM ELEMENTS

- New Development
- Residential
- Commercial Activities
- Industrial Activities
- Municipal Facilities
- Illegal Discharges



TARGETED POLLUTANTS

- High Impact
 - Medium Impact
 - Low or Unknown Impact

- Sediment
- Nutrients
- Heavy Metals
- Toxic Materials
- Oxygen Demanding Substances
- Oil & Grease
- Floatable Materials
- Bacteria & Viruses

IMPLEMENTATION REQUIREMENTS

- Capital Costs
- O&M Costs
- Regulatory
- Training
- Staffing
- Administrative

- High
- Medium
- Low

Materials Adopted From Salt Lake County Engineering Division Guidance Document

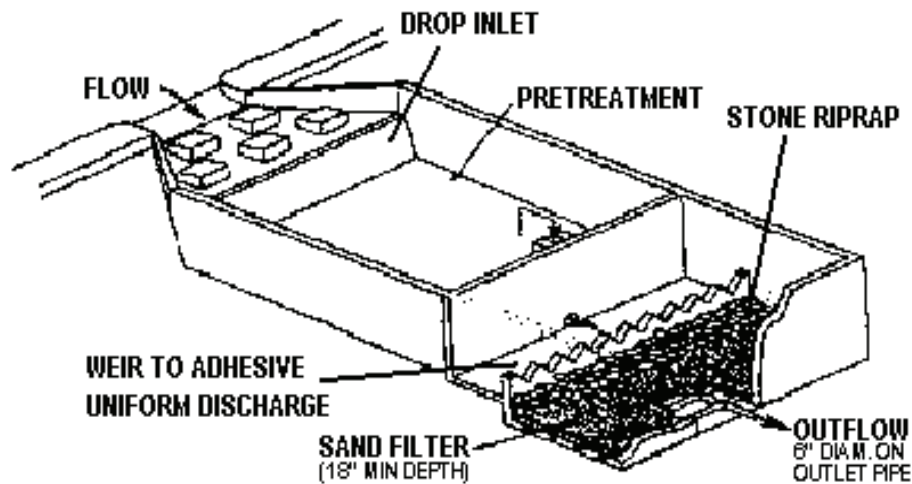

CONSIDERATIONS

- Soils
- Area Required
- Slope
- Water Availability
- Aesthetics
- Hydraulic Head
- Environmental Side Effects



DESCRIPTION:

Consists of a settling basin followed by a filter. The most common filter media is sand; some use a peat/sand mixture.

APPLICATION:

- Objective is to remove only sediment (particulate pollutants).
- Use where unavailability of water prevents the use of wet ponds, wetlands, or biofilters.
- Can be placed underground.
- Suitable for individual developments and small tributary areas up to about 100 acres.
- May require less space than other treatment control BMPs.

INSTALLATION/APPLICATION CRITERIA:

- Settling basin smaller than wet or extended detention basin.
- Spread flow across filter.
- Place filter offline to protect from extreme events.
- Minimize erosion in settling basin.

LIMITATIONS:

- Filter may require more frequent maintenance than most of the other BMPs.
- May experience significant head loss.
- Dissolved pollutants are not captured by sand.
- Severe clogging potential if exposed soil surfaces exist upstream.

MAINTENANCE:

Clean filter surface twice annually; or more often if watershed is excessively erosive.

TARGETED POLLUTANTS

- High Impact
- Medium Impact
- Low or Unknown Impact

- Sediment
- Nutrients
 - Heavy Metals
 - Toxic Materials
 - Oxygen Demanding Substances
 - Oil & Grease
 - Floatable Materials
 - Bacteria & Viruses

IMPLEMENTATION REQUIREMENTS

- Capital Costs
- O&M Costs
- Maintenance
- Training

- High • Medium • Low

Materials Adopted From Salt Lake County Engineering Division Guidance Document

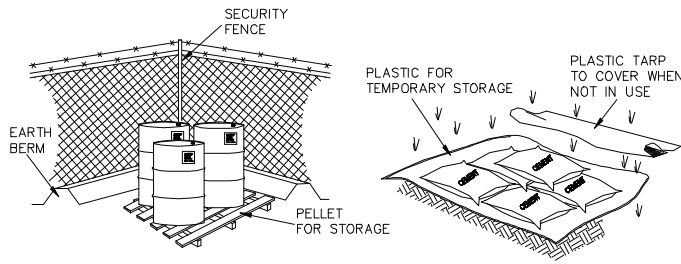

- ▶ CONTROLLED STORAGE LOCATION
- ▶ BERMED PERIMETER IMPOUNDMENT
- ▶ STORAGE OFF GROUND
- ▶ COVER WHEN NOT IN USE

OBJECTIVES

- Housekeeping Practices
- Contain Waste
- Minimize Disturbed Areas
- Stabilize Disturbed Areas
- Protect Slopes/Channels
- Control Site Perimeter
- Control Internal Erosion

DESCRIPTION:

Controlled storage of on-site materials.

APPLICATION:

- Storage of hazardous, toxic, and all chemical substances.
- Any construction site with outside storage of materials.

INSTALLATION/APPLICATION CRITERIA:

- Designate a secured area with limited access as the storage location. Ensure no waterways or drainage paths are nearby.
- Construct compacted earthen berm (See Earth Berm Barrier Information Sheet), or similar perimeter containment around storage location for impoundment in the case of spills.
- Ensure all on-site personnel utilize designated storage area. Do not store excessive amounts of material that will not be utilized on site.
- For active use of materials away from the storage area ensure materials are not set directly on the ground and are covered when not in use. Protect storm drainage during use.

LIMITATIONS:

- Does not prevent contamination due to mishandling of products.
- Spill Prevention and Response Plan still required.
- Only effective if materials are actively stored in controlled location.

MAINTENANCE:

- Inspect daily and repair any damage to perimeter impoundment or security fencing.
- Check materials are being correctly stored (i.e. standing upright, in labeled containers, tightly capped) and that no materials are being stored away from the designated location.



TARGETED POLLUTANTS

- High Impact
- Medium Impact
- Low or Unknown Impact

- Sediment
- Nutrients
- Toxic Materials
- Oil & Grease
- Floatable Materials
- Other Waste

IMPLEMENTATION REQUIREMENTS

- Capital Costs
- O&M Costs
- Maintenance
- Training

- High
- Medium
- Low

Materials Adopted From Salt Lake County Engineering Division Guidance Document



DESCRIPTION:

Applying materials such as vinyl, asphalt, plastics, or rubber on an unprotected slope to temporarily stabilize the slope.

APPLICATIONS:

- As a tacking agent to aid the stabilization of mulches (where matting is not used).
- As a short-term alternative in areas where temporary seeding practices cannot be used because of seasonal condition or climate.
- On steep and rocky slopes where neither mechanical methods or mulches and protective netting can be effectively applied.

INSTALLATION/APPLICATION CRITERIA:

- The application rates and procedures recommended by the manufacturer of a chemical stabilization product should be followed to prevent the products from forming ponds and from creating large areas where moisture cannot get through.
- For permanent application, chemical mulches (when used with seed and mulch) should be applied over wood fiber or straw mulch.

LIMITATIONS:

- Chemical mulches can create impervious surfaces and impact water quality if not properly applied.
- Some products may not be suitable for use near live streams.

MAINTENANCE:

- Inspect at regular intervals and after each runoff-producing storm event.
- Replace chemical mulch as needed to ensure adequate level of coverage.

OBJECTIVES

- Housekeeping Practices
- Contain Waste
- Minimize Disturbed Areas
- Stabilize Disturbed Areas
- Protect Slopes/Channels
- Control Site Perimeter
- Control Internal Erosion



TARGETED POLLUTANTS

- High Impact
- Medium Impact
- Low or Unknown Impact

- Sediment
- Nutrients
- Toxic Materials
- Oil & Grease
- Floatable Materials
- Other Waste

IMPLEMENTATION REQUIREMENTS

- Capital Costs
- O&M Costs
- Maintenance
- Training

■ High • Medium • Low

Materials Adapted From Salt Lake Country Engineering Division Guidance Document

Material	Application	Depth	Comments
Gravel: Washed 1/4" to 1-1/2"	9 cy/1000 sf	3 inches	Good for traffic areas Good for short slopes
Straw: Air-dried, free of seeds and coarse material	2-3 bales /1000 sf	2 inches min.	Subject to wind blowing Tack down or keep moist
Wood Fiber Cellulose: Free from growth inhibitors; dyed green	35 lb/1000 sf	1 inch	For critical areas, double application rate; Limit to slopes < 3% and < 150 feet

DESCRIPTION:

Placement of material such as straw, grass, woodchips, woodfibers or fabricated matting over open area.

APPLICATION:

- Any exposed area to remain untouched longer than 14 days and that will be exposed less than 60 days (seed areas to be exposed in excess of 60 days).
- Areas that have been seeded.
- Stockpiled soil material.

INSTALLATION/APPLICATION CRITERIA:

- Roughen area to receive mulch to create depressions that mulch material can settle into.
- Apply mulch to required thickness and anchor as necessary.
- Ensure material used is weed free and does not contain any constituents that will inhibit plant growth.

LIMITATIONS:

- Anchoring may be required to prevent migration of mulch material.
- Downgradient control may be required to prevent mulch material being transported to storm water system.

MAINTENANCE:

- Inspect mulched areas after every rainfall event and at a minimum of monthly.
- Replace mulch on any bare areas and reanchor as necessary.
- Clean and replace downgradient controls as necessary.

OBJECTIVES

- Housekeeping Practices
- Contain Waste
- Minimize Disturbed Areas
- Stabilize Disturbed Areas
- Protect Slopes/Channels
- Control Site Perimeter
- Control Internal Erosion



TARGETED POLLUTANTS

- High Impact
- Medium Impact
- Low or Unknown Impact

- Sediment
- Nutrients
- Toxic Materials
- Oil & Grease
- Floatable Materials
- Other Waste

IMPLEMENTATION REQUIREMENTS

- Capital Costs
- O&M Costs
- Maintenance
- Training

- High
- Medium
- Low

MATERIALS ADOPTED FROM SALT LAKE COUNTY ENGINEERING DIVISION GUIDANCE DOCUMENT



APPLICATIONS

- Manufacturing
- Material Handling
- Vehicle Maintenance
- Construction
- Commercial Activities
- Roadways
- Waste Containment
- Housekeeping Practices



DESCRIPTION:

Eliminate non-stormwater discharges to the stormwater collection system. Non-stormwater discharges may include: process wastewaters, cooling waters, wash waters, and sanitary wastewater.

APPROACH:

- The following approaches may be used to identify non-stormwater discharges:
- Visual inspection: the easiest method is to inspect each discharge point during dry weather. Keep in mind that drainage from a storm event can continue for three days or more and groundwater may infiltrate the underground stormwater collection system.
 - Piping Schematic Review: The piping schematic is a map of pipes and drainage systems used to carry wastewater, cooling water, sanitary wastes, etc... A review of the "as-built" piping schematic is a way to determine if there are any connections to the stormwater collection system. Inspect the path of floor drains in older buildings.
 - Smoke Testing: Smoke testing of wastewater and stormwater collection systems is used to detect connections between the two systems. During dry weather the stormwater collection system is filled with smoke and then traced to sources. The appearance of smoke at the base of a toilet indicates that there may be a connection between the sanitary and the stormwater system.
 - Dye Testing: A dye test can be performed by simply releasing a dye into either the sanitary or process wastewater system and examining the discharge points from the stormwater collection system for discoloration.

LIMITATIONS:

- Many facilities do not have accurate, up-to-date schematic drawings.
- Video and visual inspections can identify illicit connections to the storm sewer, but further testing is sometimes required (e.g. dye, smoke) to identify sources.

TARGETED POLLUTANTS

- High Impact
- Medium Impact
- Low or Unknown Impact

- Sediment
- Nutrients
- Heavy Metals
- Toxic Materials
- Oxygen Demanding Substances
- Oil & Grease
- Floatable Materials
- Bacteria & Viruses

IMPLEMENTATION REQUIREMENTS

- Capital Costs
- O&M Costs
- Maintenance
- Training

- High
- Medium
- Low

Materials Adopted From Salt Lake County Engineering Division Guidance Document

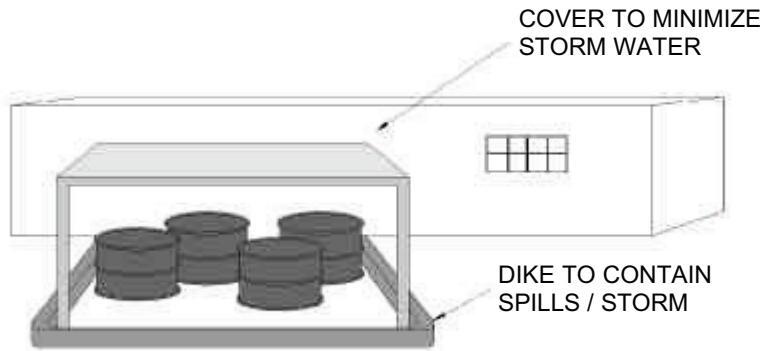

APPLICATIONS

- Manufacturing
- Material Handling
- Vehicle Maintenance
- Construction
- Commercial Activities
- Roadways
- Waste Containment
- Housekeeping Practices

DESCRIPTION:

Prevent or reduce the discharge of pollutants to stormwater from outdoor container storage areas by installing safeguards against accidental releases, installing secondary containment, conducting regular inspections, and training employees in standard operating procedures and spill cleanup techniques.

APPROACH:

Protect materials from rainfall, runoff, and wind dispersal:

- Store materials indoors.
- Cover the storage area with roof.
- Minimize stormwater runoff by enclosing the area or building a berm around it.
- Use a "doghouse" for storage of liquid containers.
- Use covered dumpsters for waste product containers.

Storage of oil and hazardous materials must meet specific federal and state standards including:

- secondary containment,
- integrity and leak detection monitoring, and
- emergency preparedness plans.

Train operator on proper storage.

Safeguards against accidental releases:

- Overflow protection devices to warn operator or automatic shut down transfer pumps, protection guards (bollards) around tanks and piping to prevent vehicle or forklift damage, clear tagging or labeling, and restricting access to valves to reduce human error.

Berm or surround tank or container with secondary containment system:

- Dikes, liners, vaults, or double walled tanks.

Some municipalities require that secondary containment areas be connected to the sanitary sewer, prohibiting any hard connections to the storm drain.

LIMITATIONS:

Storage sheds often must meet building and fire code requirements.

MAINTENANCE:

Conduct routine weekly inspections.



TARGETED POLLUTANTS

- High Impact
- Medium Impact
- Low or Unknown Impact

- Sediment
- Nutrients
- Heavy Metals
- Toxic Materials
- Oxygen Demanding Substances
- Oil & Grease
- Floatable Materials
- Bacteria & Viruses

IMPLEMENTATION REQUIREMENTS

- Capital Costs
- O&M Costs
- Maintenance
- Training

- High
- Medium
- Low

Materials Adopted From Salt Lake County Engineering Division Guidance Document



APPLICATIONS

- Manufacturing
- Material Handling
- Vehicle Maintenance
- Construction
- Commercial Activities
- Roadways
- Waste Containment
- Housekeeping Practices

DESCRIPTION:

Prevent or reduce the discharge of pollutants to stormwater from outdoor loading/unloading of materials.

APPROACH:

- Park tank trucks or delivery vehicles so that spills or leaks can be contained.
- Cover the loading/unloading docks to reduce exposure of materials to rain.
- A seal or door skirt between trailer and building can also prevent exposure to rain.
- Design loading/unloading area to prevent stormwater runoff: grade/berm and position roof downspouts to direct stormwater away from loading/unloading areas.
- Contain leaks during transfer.
- Use drip pans under hoses.
- Make sure fork lift operators are properly trained.
- Train employees for spill containment and cleanup.

LIMITATIONS:

- Space and time limitations may preclude all transfers from being performed indoors or under cover.
- It may not be possible to conduct transfers only during dry weather.

MAINTENANCE:

- Conduct regular inspections and make repairs as necessary. The frequency of repairs will depend on the age of the facility.
- Check loading and unloading equipment regularly for leaks: valves, pumps, flanges, and connections.



TARGETED POLLUTANTS

- High Impact
- Medium Impact
- Low or Unknown Impact

- Sediment
- Nutrients
- Heavy Metals
- Toxic Materials
- Oxygen Demanding Substances
- Oil & Grease
- Floatable Materials
- Bacteria & Viruses

IMPLEMENTATION REQUIREMENTS

- Capital Costs
- O&M Costs
- Maintenance
- Training

- High
- Medium
- Low

Materials Adopted From Salt Lake County Engineering Division Guidance Document

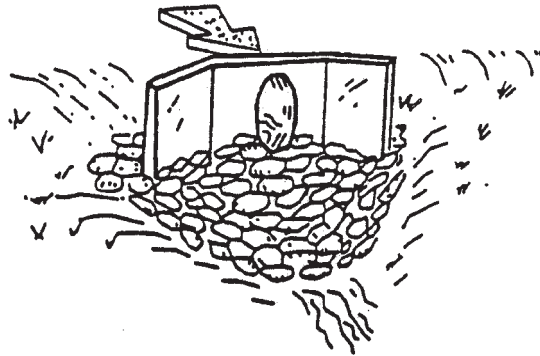

OBJECTIVES

- Housekeeping Practices
- Contain Waste
- Minimize Disturbed Areas
- Stabilize Disturbed Areas
- Protect Slopes/Channels
- Control Site Perimeter
- Control Internal Erosion



DESCRIPTION:

A rock outlet protection is a physical device composed of rock, grouted riprap, or concrete rubble which is placed at the outlet of a pipe to prevent scour of the soil caused by high pipe flow velocities, and to absorb flow energy to produce non-erosive velocities.

APPLICATIONS:

- Wherever discharge velocities and energies at the outlets of culverts, conduits, or channels are sufficient to erode the next downstream reach.
- Rock outlet protection is best suited for temporary use during construction because it is usually less expensive and easier to install than concrete aprons or energy dissipators.
- A sediment trap below the pipe outlet is recommended if runoff is sediment laden.
- Permanent rock riprap protection should be designed and sized by the engineer as part of the culvert, conduit or channel design.
- Grouted riprap should be avoided in areas of freeze and thaw because the grout will break up.

INSTALLATION/APPLICATION CRITERIA:

Rock outlet protection is effective when the rock is sized and placed properly. When this is accomplished, rock outlets do much to limit erosion at pipe outlets. Rock size should be increased for high velocity flows. Best results are obtained when sound, durable, angular rock is used.

LIMITATIONS:

- Large storms often wash away the rock outlet protection and leave the area susceptible to erosion.
- Sediment captured by the rock outlet protection may be difficult to remove without removing the rock.
- Outlet protection may negatively impact the channel habitat.

MAINTENANCE:

- Inspect after each significant rain for erosion and/or disruption of the rock, and repair immediately.
- Grouted or wire-tied rock riprap can minimize maintenance requirements.

TARGETED POLLUTANTS

- High Impact
- Medium Impact
- Low or Unknown Impact

- Sediment
- Nutrients
- Toxic Materials
- Oil & Grease
- Floatable Materials
- Other Waste

IMPLEMENTATION REQUIREMENTS

- Capital Costs
- O&M Costs
- Maintenance
- Training

- High
- Medium
- Low

MATERIALS ADOPTED FROM SALT LAKE COUNTY ENGINEERING DIVISION GUIDANCE DOCUMENT

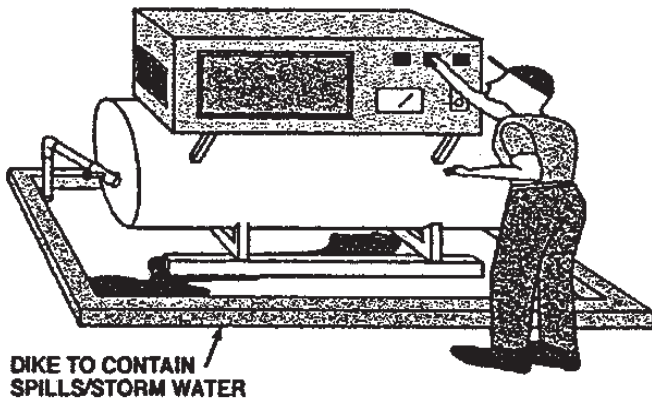

APPLICATIONS

- Manufacturing
- Material Handling
- Vehicle Maintenance
- Construction
- Commercial Activities
- Roadways
- Waste Containment
- Housekeeping Practices

DESCRIPTION:

Prevent or reduce the discharge of pollutants to stormwater from outdoor process equipment operations and maintenance by reducing the amount of waste created, enclosing or covering all or some of the equipment, installing secondary containment, and training employees.

APPROACH:

- Alter the activity to prevent exposure of pollutants to stormwater.
- Move activity indoors.
- Cover the area with a permanent roof.
- Minimize contact of stormwater with outside manufacturing operations through berming and drainage routing (runon prevention).
- Connect process equipment area to public sewer or facility wastewater treatment system.
- Clean the storm drainage system regularly.
- Use catch basin filtration inserts as a means to capture particulate pollutants.
- Some municipalities require that secondary containment areas (regardless of size) be connected to the sanitary sewer, prohibiting any hard connections to the storm drain.

LIMITATIONS:

- Providing cover may be expensive.
- Space limitations may preclude enclosing some equipment.
- Storage sheds often must meet building and fire code requirements.

MAINTENANCE:

Routine preventive maintenance, including checking process equipment for leaks.



TARGETED POLLUTANTS

- High Impact
- Medium Impact
- Low or Unknown Impact

- Sediment
- Nutrients
- Heavy Metals
- Toxic Materials
- Oxygen Demanding Substances
- Oil & Grease
- Floatable Materials
- Bacteria & Viruses

IMPLEMENTATION REQUIREMENTS

- Capital Costs
- O&M Costs
- Maintenance
- Training

- High
- Medium
- Low

Materials Adopted From Salt Lake County Engineering Division Guidance Document

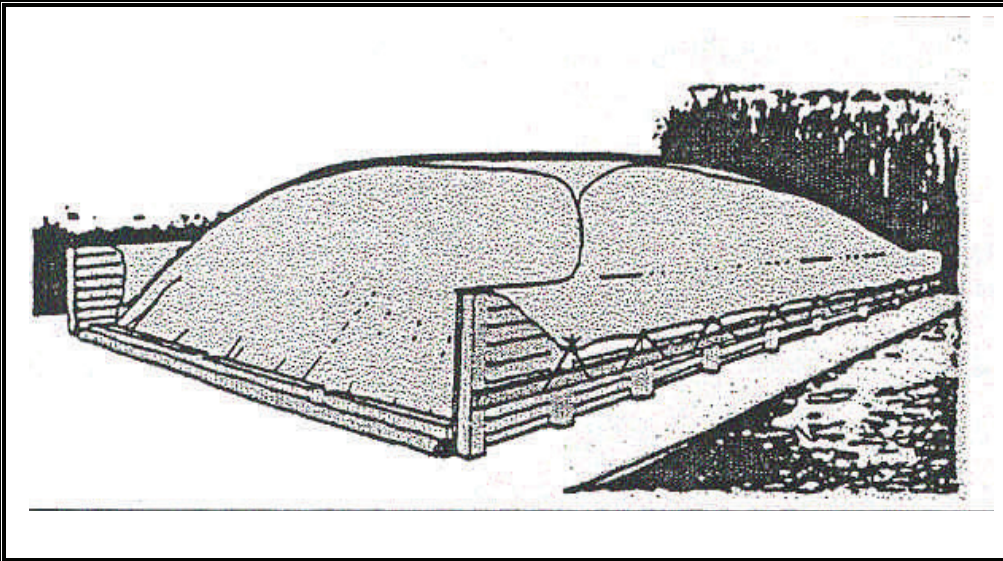

APPLICATIONS

- Manufacturing
- Material Handling
- Vehicle Maintenance
- Construction
- Commercial Activities
- Roadways
- Waste Containment
- Housekeeping Practices

DESCRIPTION:

Prevent or reduce the discharge of pollutants to stormwater from outdoor materials and product storage areas by enclosing or covering materials, installing secondary containment, and preventing stormwater runoff.

APPROACH:

Protect materials from rainfall, runoff, runoff and wind dispersal:

- Store material indoors.
- Cover the storage area with a roof.
- Cover the material with a temporary covering made of polyethylene, polypropylene, or hypalon.
- Minimize stormwater runoff by enclosing the area or building a berm around the area.
- Use a "doghouse" for storage of liquid containers.
- Parking lots or other surfaces near bulk materials should be swept periodically to remove debris blown or washed from storage area.
- Install pellet traps at stormwater discharge points where plastic pellets are loaded and unloaded.
- Keep liquids in a designated area on a paved impervious surface within a secondary containment.
- Keep outdoor storage containers in good condition.
- Use berms and curbing.
- Use catch basin filtration inserts.

LIMITATIONS:

- Space limitations may preclude storing some materials indoors.
- Some municipalities require that secondary containment areas (regardless of size) be connected to the sanitary sewer, prohibiting any hard connections to the storm drain.
- Storage sheds often must meet building and fire code requirements.

MAINTENANCE:

Berm and curbing repair and patching.



TARGETED POLLUTANTS

- High Impact
- Medium Impact
- Low or Unknown Impact

- Sediment
- Nutrients
- Heavy Metals
- Toxic Materials
- Oxygen Demanding Substances
- Oil & Grease
- Floatable Materials
- Bacteria & Viruses

IMPLEMENTATION REQUIREMENTS

- Capital Costs
- O&M Costs
- Maintenance
- Training

- High
- Medium
- Low

Materials Adopted From Salt Lake County Engineering Division Guidance Document

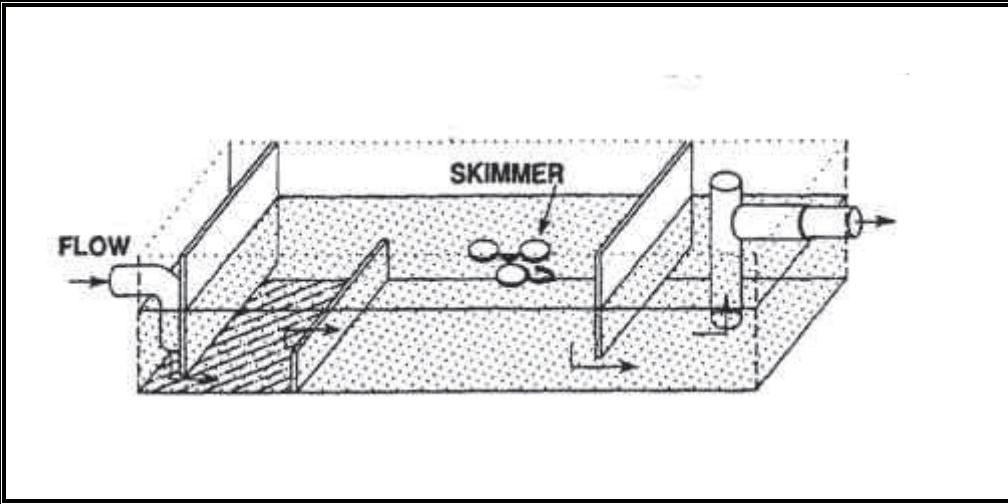

CONSIDERATIONS

- Soils
- Area Required
- Slope
- Water Availability
- Aesthetics
- Hydraulic Head
- Environmental Side Effects



DESCRIPTION:

Oil/Water separators are designed to remove specific contaminants: petroleum compounds and grease. However, separators will also remove floatable debris and settleable solids. Two general types of oil/water separators are used: conventional gravity separator and the coalescing plate interceptor (CPI).

APPLICATION:

- Applicable to situations where the concentration of oil and grease related compounds will be abnormally high and source control cannot provide effective control. The general types of businesses where this situation is likely are truck, car and equipment maintenance and washing businesses, as well as businesses that perform maintenance on their own equipment and vehicles.
- Public facilities where separators may be required include marine ports, airfields, fleet vehicle maintenance and washing facilities, and mass transit park-and-ride lots.
- Conventional separators are capable of removing oil droplets with diameters equal to greater than 150 microns.
- CPI separators should be used if smaller droplets must be removed.

INSTALLATION/APPLICATION CRITERIA:

- Sizing related to anticipated influent oil concentration, water temperature and velocity, and the effluent goal.
- To maintain reasonable separator size, it should be designed to bypass flows in excess of first flush.

LIMITATIONS:

- Little data on oil characteristics in stormwater leads to considerable uncertainty about performance.
- Air quality permit may be required.

MAINTENANCE:

Clean frequently of accumulated oil, grease, and floating debris.

TARGETED POLLUTANTS

- High Impact
- Medium Impact
- Low or Unknown Impact

- Sediment
- Nutrients
- Heavy Metals
- Toxic Materials
- Oxygen Demanding Substances
- Oil & Grease
- Floatable Materials
- Bacteria & Viruses

IMPLEMENTATION REQUIREMENTS

- Capital Costs
- O&M Costs
- Maintenance
- Training

- High
- Medium
- Low

Materials Adopted From Salt Lake County Engineering Division Guidance Document

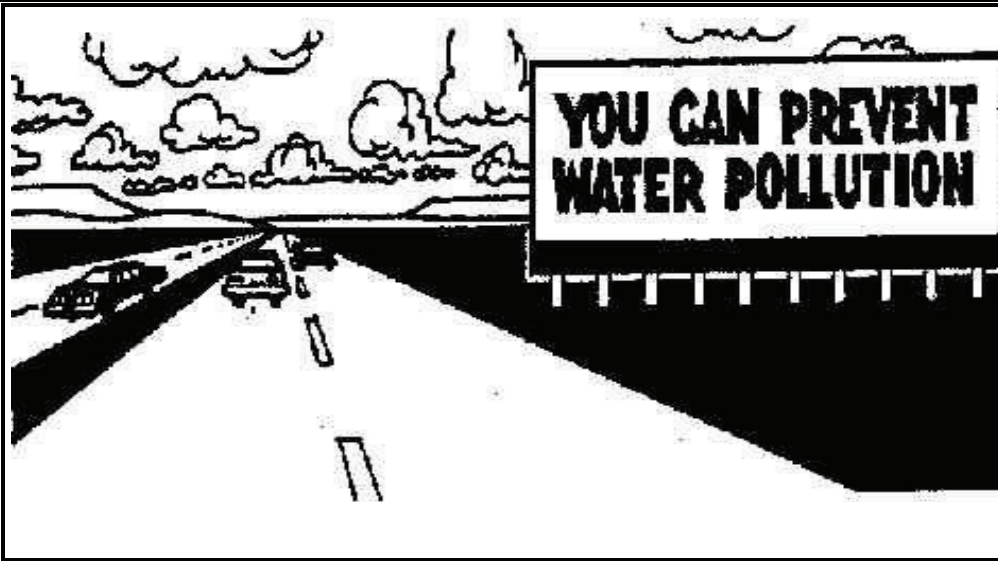

DESCRIPTION:

Public education/participation, like an ordinance or a piece of equipment, is not so much a best management practice as it is a method by which to implement BMPs. This information sheet highlights the importance of integrating elements of public education and participation into a municipality's overall plan for stormwater quality management.

A public education and participation plan provides the municipality with a strategy for educating its employees, the public, and businesses about the importance of protecting stormwater from improperly used, stored, and disposed of pollutants. Municipal employees must be trained, especially those that work in departments not directly related to stormwater but whose actions affect stormwater. Residents must become aware that a variety of hazardous products are used in the home and that their improper use and disposal can pollute stormwater. Increased public awareness also facilitates public scrutiny of industrial and municipal activities and will likely increase public reporting of incidents.

APPROACH:

- Pattern a new program after the many established programs around the country.
- Implement public education/participation as a coordinated campaign in which each message is related to the last.
- Present a clear and consistent message and image to the public regarding how they contribute to stormwater pollution and what they can do to reduce it.
- Utilize multi-media to reach the full range of audiences.
- Translate messages into the foreign languages of the community to reach the full spectrum of your populace and to avoid misinterpretation of messages.
- Create an awareness and identification with the local watershed.
- Use everyday language in all public pieces. Use outside reviewers to highlight and reduce the use of technical terminology, acronyms, and jargon.
- Make sure all statements have a sound, up-to-date technical basis. Do not contribute to the spread of misinformation.
- Break complicated subjects into smaller more simple concepts. Present these concepts to the public in a metered and organized way to avoid "overloading" and confusing the audience.

PROGRAM ELEMENTS

- New Development
- Residential
- Commercial Activities
- Industrial Activities
- Municipal Facilities
- Illegal Discharges



TARGETED POLLUTANTS

- High Impact
- Medium Impact
- Low or Unknown Impact

- Sediment
- Nutrients
- Heavy Metals
- Toxic Materials
- Oxygen Demanding Substances
- Oil & Grease
- Floatable Materials
- Bacteria & Viruses

IMPLEMENTATION REQUIREMENTS

- Capital Costs
- O&M Costs
- Regulatory
- Training
- Staffing
- Administrative

- High
- Medium
- Low

Materials Adopted From Salt Lake County Engineering Division Guidance Document

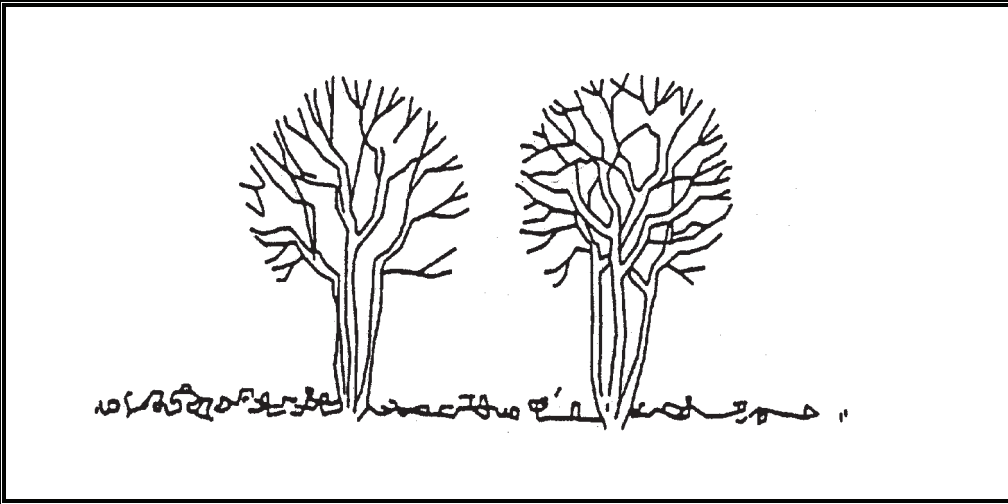

OBJECTIVES

- Housekeeping Practices
- Contain Waste
- Minimize Disturbed Areas
- Stabilize Disturbed Areas
- Protect Slopes/Channels
- Control Site Perimeter
- Control Internal Erosion

GENERAL DESCRIPTION:

Carefully planned preservation of existing vegetation minimizes the potential of removing or injuring existing trees, vines, shrubs and/or grasses that serve as erosion controls.

APPLICATIONS:

This technique is applicable to all types of sites. Areas where preserving vegetation can be particularly beneficial are floodplains, wetlands, stream banks, steep slopes, and other areas where erosion controls would be difficult to establish, install, or maintain.

INSTALLATION/APPLICATION CRITERIA:

- Clearly mark, flag or fence vegetation or areas where vegetation should be preserved.
- Prepare landscaping plans which include as much existing vegetation as possible and state proper care during and after construction.
- Define and protect with berms, fencing, signs, etc. a setback area from vegetation to be preserved.
- Propose landscaping plans which do not include plant species that compete with the existing vegetation.
- Do not locate construction traffic routes, spoil piles, etc. where significant adverse impact on existing vegetation may occur.

LIMITATIONS:

- Requires forward planning by the owner/developer, contractor and design staff.
- For sites with diverse topography, it is often difficult and expensive to save existing trees while grading the site satisfactorily for the planned development.
- May not be cost effective with high land costs.

MAINTENANCE:

- Inspection and maintenance requirements for protection of vegetation are low.
- Maintenance of native trees or vegetation should conform to landscape plan specifications.



TARGETED POLLUTANTS

- High Impact
- Medium Impact
- Low or Unknown Impact

- Sediment
- Nutrients
- Toxic Materials
- Oil & Grease
- Floatable Materials
- Other Waste

IMPLEMENTATION REQUIREMENTS

- Capital Costs
- O&M Costs
- Maintenance
- Training

- High
- Medium
- Low

Materials Adopted From Salt Lake County Engineering Division Guidance Document

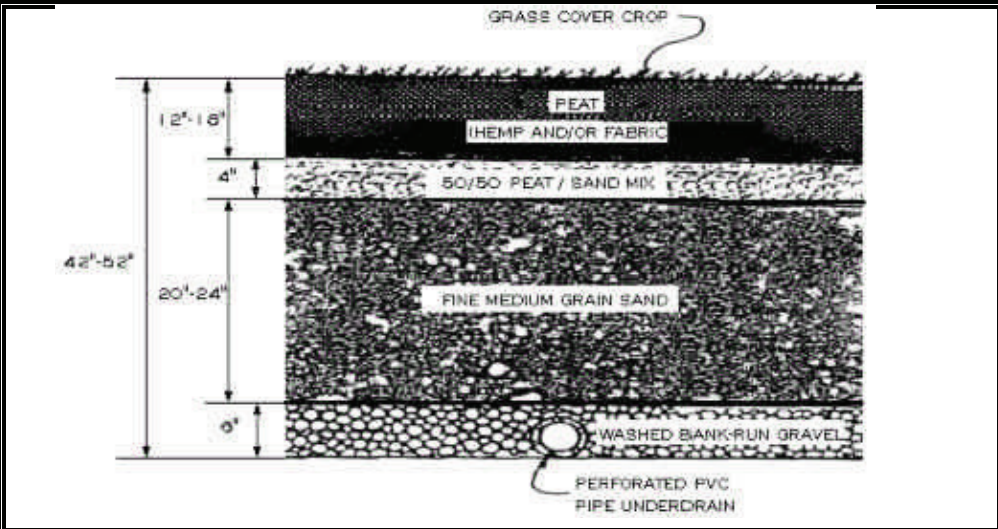

CONSIDERATIONS

- Soils
- Area Required
- Slope
- Water Availability
- Aesthetics
- Hydraulic Head
- Environmental Side Effects



DESCRIPTION:

A filter system containing fibric or hemic peat and consisting of a sedimentation chamber or pond, a surface vertical filter system, a grass cover crop, and alternating layers of peat and sand all underlain by collector pipes in a gravel bed.

APPLICATION:

- Development where insufficient space exists for a wet pond.
- Development where higher rates of pollutant removal are preferred.

INSTALLATION/APPLICATION CRITERIA:

- Use only fibric or hemic peat. Sapric peat will result in system failure.
- Can be used in high water table areas.
- Peat will not remove pollutants if it becomes oxygen depleted.

LIMITATIONS:

- Suitable peat material may not always be available.
- System must be shut down during the winter months.
- Sites with little or no gradient may prevent sufficient gravity flow through the system.
-

MAINTENANCE:

- During dry seasons or periods of drought the cover crop may require irrigation.
- Remove silt when accumulation exceeds 6" (15.2 cm).
 - Remove accumulated trash and debris every 6 months or as necessary.

TARGETED POLLUTANTS

- High Impact
- Medium Impact
- Low or Unknown Impact

- Sediment
- Nutrients
- Heavy Metals
- Toxic Materials
- Oxygen Demanding Substances
- Oil & Grease
- Floatable Materials
- Bacteria & Viruses

IMPLEMENTATION REQUIREMENTS

- Capital Costs
- O&M Costs
- Maintenance
- Training

- High
- Medium
- Low

Materials Adopted From Salt Lake County Engineering Division Guidance Document

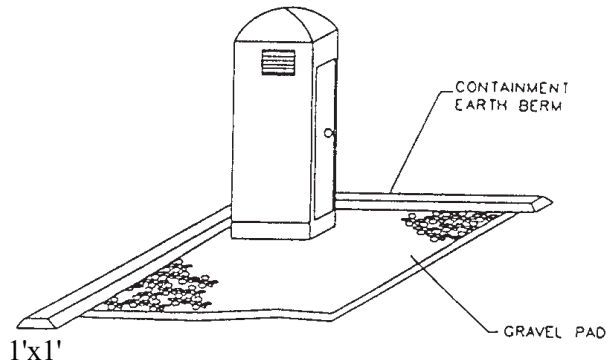

OBJECTIVES

- Housekeeping Practices
- Contain Waste
- Minimize Disturbed Areas
- Stabilize Disturbed Areas
- Protect Slopes/Channels
- Control Site Perimeter
- Control Internal Erosion

DESCRIPTION:

Temporary on-site sanitary facilities for construction personnel.

APPLICATION:

All sites with no permanent sanitary facilities or where permanent facility is too far from activities.

INSTALLATION/APPLICATION CRITERIA:

- Locate portable toilets in convenient locations throughout the site.
- Prepare level, gravel surface and provide clear access to the toilets for servicing and for on-site personnel.
- **Place toilet behind the sidewalk or at least 8' away from any impervious area**

LIMITATIONS:

No limitations.

MAINTENANCE:

- Portable toilets should be maintained in good working order by licensed service with daily observation for leak detection.
- Regular waste collection should be arranged with licensed service.
- All waste should be deposited in sanitary sewer system for treatment with appropriate agency approval.



TARGETED POLLUTANTS

- High Impact
- Medium Impact
- Low or Unknown Impact

- Sediment
- Nutrients
- Toxic Materials
- Oil & Grease
- Floatable Materials
- Other Waste

IMPLEMENTATION REQUIREMENTS

- Capital Costs
- O&M Costs
- Maintenance
- Training

- High
- Medium
- Low

MATERIALS ADOPTED FROM SSALT LAKE COUNTY ENGINEERING DIVISION GUIDANCE DOCUMENT

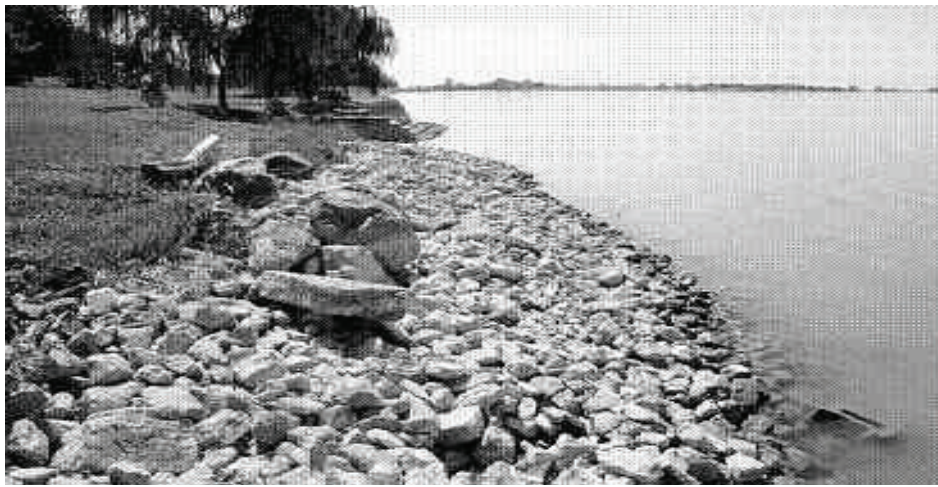

CONSIDERATIONS

- Soils
- Area Required
- Slope
- Water Availability
- Aesthetics
- Hydraulic Head
- Environmental Side Effects



DESCRIPTION:

Riprap is a permanent, erosion-resistant protective layer made of loose stones. It is intended to protect soil from erosion in areas of concentrated runoff. Riprap may also be used to stabilize slopes that are unstable because of seepage problems.

APPLICATION:

- Riprap is normally used at locations where erosive forces from water flow exceed the ability of the soil or vegetative cover to resist those forces.
- Riprap can be used for pipe outlet protection, channel lining, scour protection, etc.
- Riprap is commonly used for wave protection on lakes.

INSTALLATION/APPLICATION CRITERIA:

- For slopes steeper than 2:1, consider using materials other than riprap for erosion protection.
- If riprap is being planned for the bottom of a permanently flowing channel, the bottom can be modified to enhance fish habitat. This can be done by constructing riffles and pools which simulate natural conditions.
- When working within flowing streams, measures should be taken to prevent excessive turbidity and erosion during construction. Bypassing base flows or temporarily blocking base flows are two possible methods. Work should be done during a period of low flow.

In designing riprap consider the following:

- Use durable rock, such as granite, and a variety of rock sizes.
- The thickness of riprap layers should be at least 1.25 times the max. stone diameter.
- Filter material is usually required between riprap and the underlying soil surface.

LIMITATIONS:

- Riprap may be unstable on very steep slopes.
- The placement of a riprap in streams requires a state stream alteration permit.

MAINTENANCE:

- Riprap should be inspected annually and after major storms.
- If riprap has been damaged, repairs should be made promptly to prevent a progressive failure.
- If repairs are needed repeatedly at one location, the site should be evaluated to see if original design conditions have changed.

TARGETED POLLUTANTS

- High Impact
- Medium Impact
- Low or Unknown Impact

- Sediment
- Nutrients
- Heavy Metals
- Toxic Materials
- Oxygen Demanding Substances
- Oil & Grease
- Floatable Materials
- Bacteria & Viruses

IMPLEMENTATION REQUIREMENTS

- Capital Costs
- O&M Costs
- Maintenance
- Training

- High
- Medium
- Low

Materials Adopted from Salt Lake County Engineering Division Guidance Document

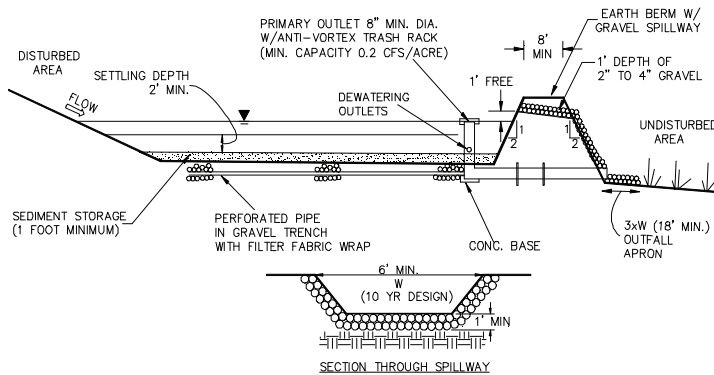

OBJECTIVES

- Housekeeping Practices
- Contain Waste
- Minimize Disturbed Areas
- Stabilize Disturbed Areas
- Protect Slopes/Channels
- Control Site Perimeter
- Control Internal Erosion

DESCRIPTION:

A pond created by excavation or construction of an embankment, and designed to retain or detain runoff sufficiently to allow excessive sediment to settle.

APPLICATION:

- At the outlet of all disturbed watersheds 10 acres or larger.
- At the outlet of smaller disturbed watersheds, as necessary.
- Where post construction detention basins will be located.

INSTALLATION/APPLICATION CRITERIA:

- Design basin for site specific location, maintain effective flow length 2 times width.
- Excavate basin or construct compacted berm containment, ensure no downgradient hazard if failure should occur. (Provide minimum of 67 cy. per acre of drainage area).
- Construct dewatering and outfall structure and emergency spillway with apron.

LIMITATIONS:

- Should be sized based on anticipated runoff, sediment loading and drainage area size.
- May require silt fence at outlet for entrapment of very fine silts and clays.
- May require safety fencing to prevent public access.
- Height restrictions for embankment regulated by Utah Division of Dam Safety.

MAINTENANCE:

- Inspect after each rainfall event and at a minimum of monthly.
- Repair any damage to berm, spillway or sidewalls.
- Remove accumulated sediment as it reaches 2/3 height of available storage.
- Check outlet for sedimentation/erosion of downgradient area and remediate as necessary. Install silt fence if sedimentation apparent.



TARGETED POLLUTANTS

- High Impact
- Medium Impact
- Low or Unknown Impact

- Sediment
- Nutrients
- Toxic Materials
- Oil & Grease
- Floatable Materials
- Other Waste

IMPLEMENTATION REQUIREMENTS

- Capital Costs
- O&M Costs
- Maintenance
- Training

- High
- Medium
- Low

Materials Adopted From Salt Lake County Engineering Division Guidance Document

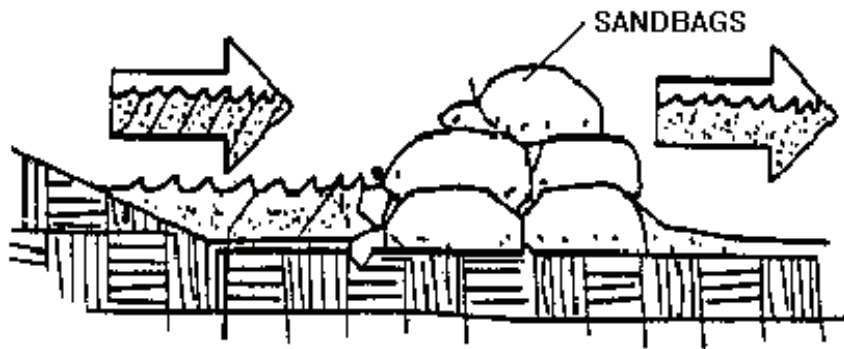

DESCRIPTION:

Stacking sand bags along a level contour creates a barrier which detains sediment-laden water, ponding water upstream of the barrier and promoting sedimentation.

APPLICATION:

- Along the perimeter of the site.
- May be used in drainage areas up to 5 acres.
- Along streams and channels
- Across swales with small catchments.
- Around temporary spoil areas.
- Below the toe of a cleared slope.

INSTALLATION/APPLICATION CRITERIA:

- Install along a level contour.
- Base of sand bag barrier should be at least 48 inches wide.
- Height of sand bag barrier should be at least 18 inches high.
- 4 inch PVC pipe may be installed between the top layer of sand bags to drain large flood flows.
- Provide area behind barrier for runoff to pond and sediment to settle.
- Place below the toe of a slope.

LIMITATIONS:

- Sand bags are more expensive than other barriers, but also more durable.
- Burlap should not be used.

MAINTENANCE:

- Inspect after each rain.
- Reshape or replace damaged sand bags immediately.
- Replace sediment when it reaches six inches in depth.

OBJECTIVES

- Housekeeping Practices
- Contain Waste
- Minimize Disturbed Areas
- Stabilize Disturbed Areas
- Protect Slopes/Channels
- Control Site Perimeter
- Control Internal Erosion



TARGETED POLLUTANTS

- High Impact
- Medium Impact
- Low or Unknown Impact

- Sediment
- Nutrients
- Toxic Materials
- Oil & Grease
- Floatable Materials
- Other Waste

IMPLEMENTATION REQUIREMENTS

- Capital Costs
- O&M Costs
- Maintenance
- Training

- High
- Medium
- Low

Materials Adopted From Salt Lake County Engineering Division Guidance Document



PROGRAM ELEMENTS

- New Development
- Residential
- Commercial Activities
- Industrial Activities
- Municipal Facilities
- Illegal Discharges



DESCRIPTION:

Reduce the discharges of pollutants to stormwater from street surfaces by conducting street cleaning on a regular basis.

APPROACH:

- Prioritize cleaning to use the most sophisticated sweepers, at the highest frequency, and in areas with the highest pollutant loading.
- Restrict street parking prior to and during sweeping.
- Increase sweeping frequency just before the rainy season.
- Proper maintenance and operation of sweepers greatly increase their efficiency.
- Keep accurate operation logs to track programs.
- Reduce the number of parked vehicles using regulations.
- Sweepers effective at removing smaller particles (less than 10 microns) may generate dust that would lead to concerns over worker and public safety.
- Equipment selection can be key for this particular BMP. There are two types used, the mechanical broom sweepers (more effective at picking up large debris and cleaning wet streets), and the vacuum sweepers (more effective at removing fine particles and associated heavy metals). Many communities find it useful to have a compliment of both types in their fleet.

LIMITATIONS:

- Conventional sweepers are not able to remove oil and grease.
- Mechanical sweepers are not effective at removing finer sediments.
- Effectiveness may also be limited by street conditions, traffic congestion, presence of construction projects, climatic conditions and condition of curbs.

MAINTENANCE:

- Replace worn parts as necessary.
- Install main and gutter brooms of the appropriate weight.

TARGETED POLLUTANTS

- High Impact
- Medium Impact
- Low or Unknown Impact

- Sediment
- Nutrients
- Heavy Metals
- Toxic Materials
- Oxygen Demanding Substances
- Oil & Grease
- Floatable Materials
- Bacteria & Viruses

IMPLEMENTATION REQUIREMENTS

- Capital Costs
- O&M Costs
- Regulatory
- Training
- Staffing
- Administrative

- High
- Medium
- Low

Materials Adopted From Salt Lake County Engineering Division Guidance Document

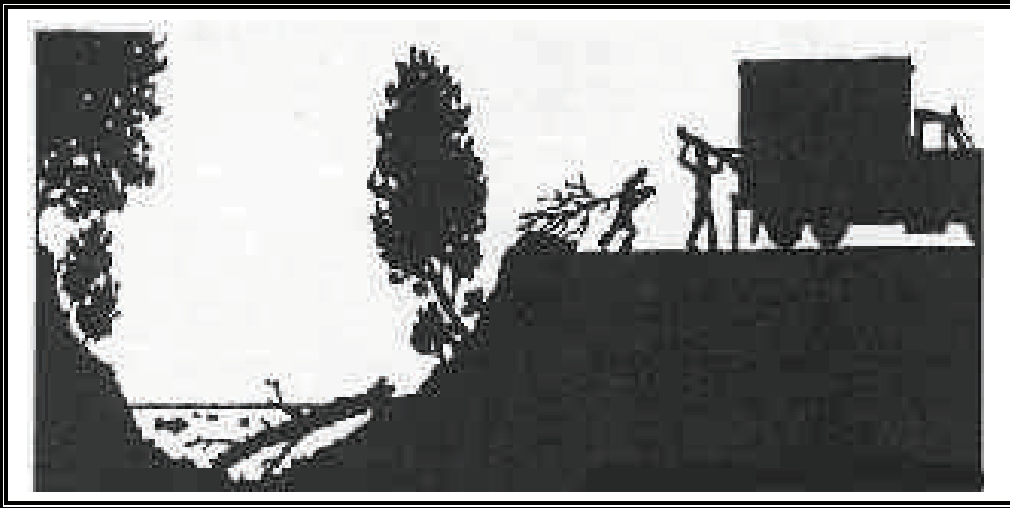

DESCRIPTION:

Reduce pollutant levels in stormwater by removing illegally dumped items and material from storm drainage channels and creeks. Modify channel characteristics to enhance pollutant removal and/or hydraulic capacity.

APPROACH:

- Identify illegal dumping hot spots; regular inspection and clean up of hot spots and other storm drainage areas where illegal dumping and disposal occurs.
- Post “No Littering” signs with a phone number for reporting a dumping in-progress.
- Adopt and enforce substantial penalties for illegal dumping and disposal.
- Modify storm channel characteristics to improve channel hydraulics, to increase pollutant removals, and to enhance channel/creek aesthetics and habitat value.
- Maintain accurate logs to evaluate materials removed and improvements made.

LIMITATIONS:

- Clean-up activities may create a slight disturbance for local aquatic species.
- Access to items and material on private property may be limited.
- Trade-offs may exist between channel hydraulics and water quality/riparian habitat.
- Worker/public safety may be at risk in crime-ridden areas.
- If storm channels or basins are recognized as wetlands, many activities, including maintenance, may be subject to regulation.

PROGRAM ELEMENTS

- New Development
- Residential
- Commercial Activities
- Industrial Activities
- Municipal Facilities
- Illegal Discharges



TARGETED POLLUTANTS

- High Impact
- Medium Impact
- Low or Unknown Impact

- Sediment
- Nutrients
- Heavy Metals
- Toxic Materials
- Oxygen Demanding Substances
- Oil & Grease
- Floatable Materials
- Bacteria & Viruses

IMPLEMENTATION REQUIREMENTS

- Capital Costs
- O&M Costs
- Regulatory
- Training
- Staffing
- Administrative

- High
- Medium
- Low

Materials Adopted From Salt Lake County Engineering Division Guidance Document

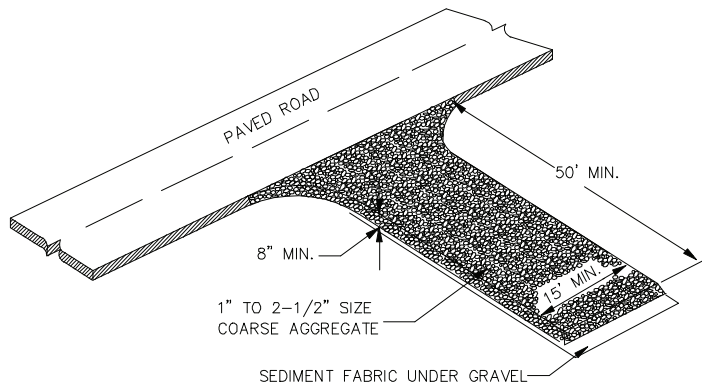

OBJECTIVES

- Housekeeping Practices
- Contain Waste
- Minimize Disturbed Areas
- Stabilize Disturbed Areas
- Protect Slopes/Channels
- Control Site Perimeter
- Control Internal Erosion



DESCRIPTION:

A stabilized pad of crushed stone located where construction traffic enters or leaves the site from or to paved surface.

APPLICATIONS:

At any point of ingress or egress at a construction site where adjacent traveled way is paved. Generally applies to sites over 2 acres unless special conditions exist.

INSTALLATION/APPLICATION CRITERIA:

- Clear and grub area and grade to provide maximum slope of 2%.
- Compact subgrade and place filter fabric if desired (recommended for entrances to remain for more than 3 months).
- Place coarse aggregate, 1 to 2-1/2 inches in size, to a minimum depth of 8 inches.

LIMITATIONS:

- Requires periodic top dressing with additional stones.
- Should be used in conjunction with street sweeping on adjacent public right-of-way.

MAINTENANCE:

- Inspect daily for loss of gravel or sediment buildup.
- Inspect adjacent roadway for sediment deposit and clean by sweeping or shoveling.
- Repair entrance and replace gravel as required to maintain control in good working condition.
- Expand stabilized area as required to accommodate traffic and prevent erosion at driveways.

TARGETED POLLUTANTS

- High Impact
- Medium Impact

- Sediment
- Nutrients
- Toxic Materials
- Oil & Grease
- Floatable Materials
- Other Waste

IMPLEMENTATION REQUIREMENTS

- Capital Costs
- O&M Costs
- Maintenance
- Training

- High
- Medium
- Low

MATERIALS ADOPTED FROM SSALT LAKE COUNTY ENGINEERING DIVISION GUIDANCE DOCUMENT

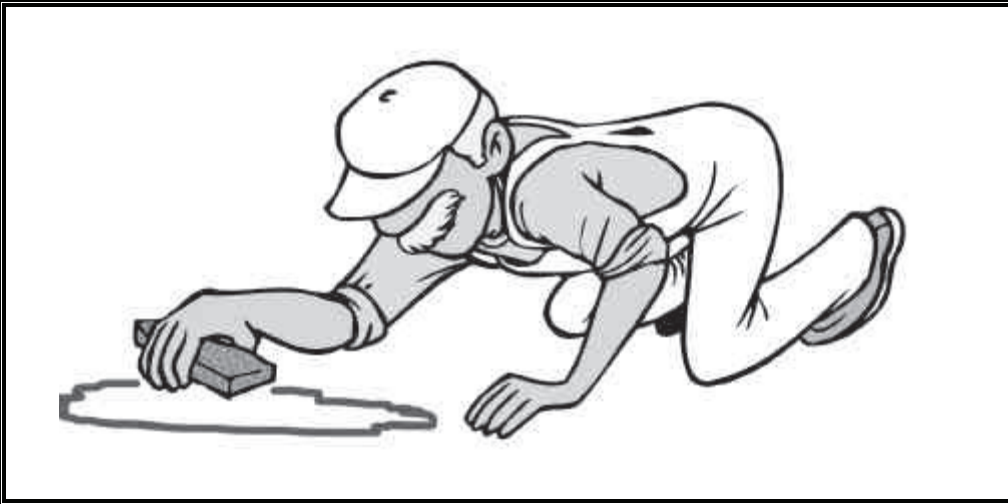

OBJECTIVES

- Housekeeping Practices
- Contain Waste
- Minimize Disturbed Areas
- Stabilize Disturbed Areas
- Protect Slopes/Channels
- Control Site Perimeter
- Control Internal Erosion



DESCRIPTION:

Practices to clean-up leakage/spillage of on-site materials that may be harmful to receiving waters.

APPLICATION:

All sites

GENERAL:

- Store controlled materials within a storage area.
- Educate personnel on prevention and clean-up techniques.
- Designate an Emergency Coordinator responsible for employing preventative practices and for providing spill response.
- Maintain a supply of clean-up equipment on-site and post a list of local response agencies with phone numbers.

METHODS:

- Clean-up spills/leaks immediately and remediate cause.
- Use as little water as possible. NEVER HOSE DOWN OR BURY SPILL CONTAMINATED MATERIAL.
- Use rags or absorbent material for clean-up. Excavate contaminated soils. Dispose of clean-up material and soil as hazardous waste.
- Document all spills with date, location, substance, volume, actions taken and other pertinent data.
- Contact local Fire Department and State Division of Environmental Response and Remediation (Phone #536-4100) for any spill of reportable quantity.

TARGETED POLLUTANTS

- High Impact
- Medium Impact
- Low or Unknown Impact

- Sediment
- Nutrients
- Toxic Materials
- Oil & Grease
- Floatable Materials
- Other Waste

IMPLEMENTATION REQUIREMENTS

- Capital Costs
- O&M Costs
- Maintenance
- Training

- High
- Medium
- Low

Materials Adopted From Salt Lake County Engineering Division Guidance Document

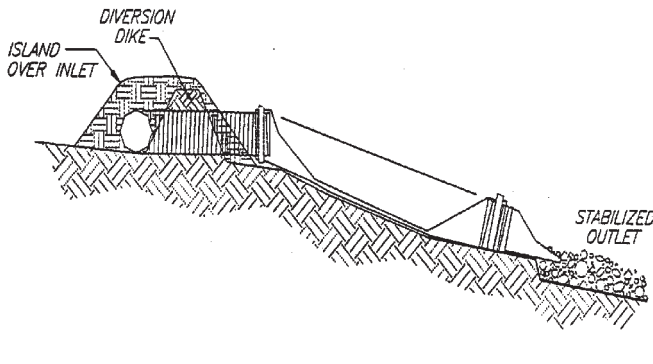

DESCRIPTION:

A temporary pipe or lined channel that drains the top of a slope to a stable discharge point at the bottom of a slope without causing erosion.

APPLICATIONS:

- Where concentrated flow of surface runoff must be conveyed down a slope in order to prevent erosion.
- Drainage for top slope diversion dikes or swales.
- Emergency spillway for a sediment basin.
- Drainage for top of cut/fill slopes where water can accumulate.

INSTALLATION/APPLICATION CRITERIA:

- Secure inlet and surround with dikes to prevent gully erosion, and anchor pipe to slope.
- Size to convey at least the peak of a 10-year, storm event.
- Stabilize outlet. (See Outlet Protection BMP).

LIMITATIONS:

- Maximum drainage area per slope drain is 5 acres.
- Clogged slope drains will force water around the pipe and cause slope erosion.
- Dissipation of high flow velocities at the pipe outlet is required to avoid downstream erosion.
- Failure can result in flooding and severe erosion.

MAINTENANCE:

- Structure must be inspected weakly and after storms.
- Inlet must be free of undercutting and no water should circumvent the entry.
- Outlet should not produce erosion; velocity dissipators must be maintained.
- Pipe anchors must be checked to ensure that the pipe remains anchored to the slope.

OBJECTIVES

- Housekeeping Practices
- Contain Waste
- Minimize Disturbed Areas
- Stabilize Disturbed Areas
- Protect Slopes/Channels
- Control Site Perimeter
- Control Internal Erosion



TARGETED POLLUTANTS

- High Impact
- Medium Impact
- Low or Unknown Impact

- Sediment
- Nutrients
- Toxic Materials
- Oil & Grease
- Floatable Materials
- Other Waste

IMPLEMENTATION REQUIREMENTS

- Capital Costs
- O&M Costs
- Maintenance
- Training

- High
- Medium
- Low

Materials Adopted From Salt Lake County Engineering Division Guidance Document

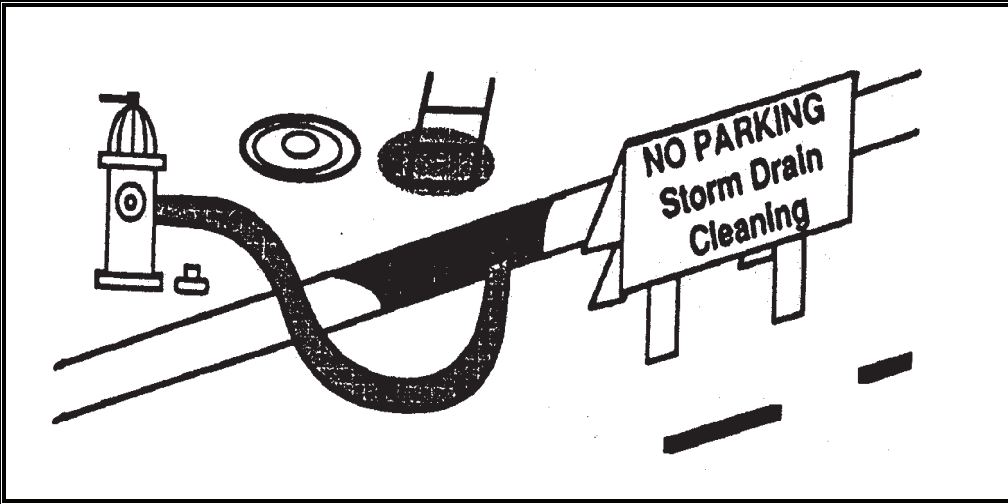

DESCRIPTION:

A storm drain is "flushed" with water to suspend and remove deposited materials. Flushing is particularly beneficial for storm drain pipes with grades too flat to be self-cleansing. Flushing helps ensure pipes convey design flow and remove pollutants from the storm drain system.

APPROACH:

- Locate reaches of storm drain with deposit problems and develop a flushing schedule that keeps the pipe clear of excessive buildup.
- Whenever possible, flushed effluent should be collected, decanted, evaporated, and disposed of in a landfill.

LIMITATIONS:

- Most effective in small diameter pipes (36-inch diameter pipe or less, depending on water supply and sediment collection capacity).
- Water source must be available.
- May have difficulty finding downstream area to collect sediments.
- Requires liquid/sediment disposal.

PROGRAM ELEMENTS

- New Development
- Residential
- Commercial Activities
- Industrial Activities
- Municipal Facilities
- Illegal Discharges



TARGETED POLLUTANTS

- High Impact
- Medium Impact
- Low or Unknown Impact

- Sediment
- Nutrients
- Heavy Metals
- Toxic Materials
- Oxygen Demanding Substances
- Oil & Grease
- Floatable Materials
- Bacteria & Viruses

IMPLEMENTATION REQUIREMENTS

- Capital Costs
- O&M Costs
- Regulatory
- Training
- Staffing
- Administrative

- High
- Medium
- Low

Materials Adopted From Salt Lake County Engineering Division Guidance Document



PROGRAM ELEMENTS

- New Development
- Residential
- Commercial Activities
- Industrial Activities
- Municipal Facilities
- Illegal Discharges



DESCRIPTION:

Stenciling of the storm drain system (inlets, catch basins, channels, and creeks) with prohibitive language/graphic icons discourages the illegal dumping of unwanted materials.

APPROACH:

- Create a volunteer work force to stencil storm drain inlets.
- An important aspect of a stenciling program is the distribution of informational flyers that educate the neighborhood (business and residential) about stormwater pollution, the storm drain system, and the watershed. The flyers should also provide information on alternatives such as recycling, household hazardous waste disposal, and safer products.
- Because a stenciling program primarily involves volunteer services, liability release forms and volunteer identification notices should also be administered.
- Readability of stencils is critical to their effectiveness. Wherever possible stencils should be painted on a smooth surface such as cement, as opposed to asphalt.
- Use municipal staff to erect signs near drainage channels and creeks.
- An effectively implemented stenciling program encourages change in personal behavior and helps minimize non-point source pollutants from entering the storm drain system. An additional benefit is that waste and catch basin maintenance is minimized through the reduction of disposed materials into storm drain inlets. Finally a well-implemented stenciling program encourages the use of household hazardous waste collection and used oil recycling programs.

LIMITATIONS:

- Private property access limits stenciling to publicly-owned areas.
- Program is highly dependent on volunteer response.
- Storm drain inlets that are physically blocked will be missed or require follow-up.
- High traffic/commercial/industrial zones are the responsibility of city staff.
- Ongoing maintenance is needed to maintain readable signs.

TARGETED POLLUTANTS

- High Impact
 - Medium Impact
 - Low or Unknown Impact

- Sediment
- Nutrients
- Heavy Metals
- Toxic Materials
- Oxygen Demanding Substances
- Oil & Grease
- Floatable Materials
- Bacteria & Viruses

IMPLEMENTATION REQUIREMENTS

- Capital Costs
- O&M Costs
- Regulatory
- Training
- Staffing
- Administrative

■ High • Medium • Low

Materials Adopted From Salt Lake County Engineering Division Guidance Document

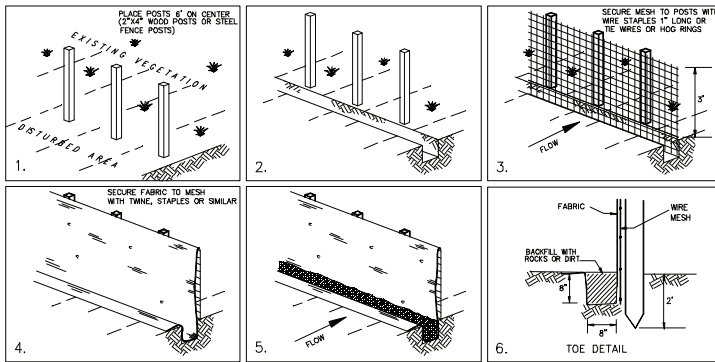

OBJECTIVES

- Housekeeping Practices
- Contain Waste
- Minimize Disturbed Areas
- Stabilize Disturbed Areas
- Protect Slopes/Channels
- Control Site Perimeter
- Control Internal Erosion

DESCRIPTION:

A temporary sediment barrier consisting of entrenched filter fabric stretched across and secured to supporting posts.

APPLICATION:

- Perimeter control: place barrier at downgradient limits of disturbance
- Sediment barrier: place barrier at toe of slope or soil stockpile
- Protection of existing waterways: place barrier at top of stream bank
- Inlet protection: place fence surrounding catchbasins

INSTALLATION/APPLICATION CRITERIA:

- Place posts 6 feet apart on center along contour (or use preassembled unit) and drive 2 feet minimum into ground. Excavate an anchor trench immediately upgradient of posts.
- Secure wire mesh (14 gage min. With 6 inch openings) to upslope side of posts. Attach with heavy duty 1 inch long wire staples, tie wires or hog rings.
- Cut fabric to required width, unroll along length of barrier and drape over barrier. Secure fabric to mesh with twine, staples, or similar, with trailing edge extending into anchor trench.
- Backfill trench over filter fabric to anchor.

LIMITATIONS:

- Recommended maximum drainage area of 0.5 acre per 100 feet of fence
- Recommended maximum upgradient slope length of 150 feet
- Recommended maximum uphill grade of 2:1 (50%)
- Recommended maximum flow rate of 0.5 cfs
- Ponding should not be allowed behind fence

MAINTENANCE:

- Inspect immediately after any rainfall and at least daily during prolonged rainfall.
- Look for runoff bypassing ends of barriers or undercutting barriers.
- Repair or replace damaged areas of the barrier and remove accumulated sediment.
- Reanchor fence as necessary to prevent shortcutting.
- Remove accumulated sediment when it reaches 1/2 the height of the fence.



TARGETED POLLUTANTS

- High Impact
- Medium Impact
- Low or Unknown Impact

- Sediment
- Nutrients
- Toxic Materials
- Oil & Grease
- Floatable Materials
- Other Waste

IMPLEMENTATION REQUIREMENTS

- Capital Costs
- O&M Costs
- Maintenance
- Training

- High
- Medium
- Low

Materials Adopted From Salt Lake County Engineering Division Guidance Document

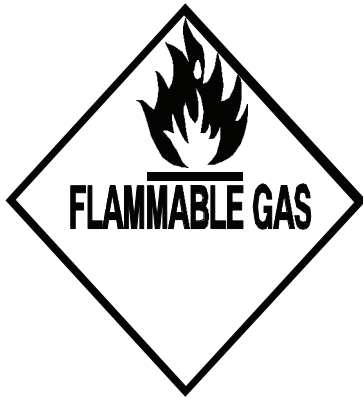

APPLICATIONS

- Manufacturing
- Material Handling
- Vehicle Maintenance
- Construction
- Commercial Activities
- Roadways
- Waste Containment
- Housekeeping Practices



DESCRIPTION:

Signs and labels identify problem areas or hazardous materials at a facility. Warning signs, often found at industrial facilities, are a good way to suggest caution in certain areas. Signs and labels can also provide instructions on the use of materials and equipment. Labeling is a good way to organize large amounts of materials, pipes, and equipment, particularly on large sites.

APPROACH:

Signs and labels can be used at all types of facilities. Areas where they are particularly useful are material transfer areas, equipment areas, loading and unloading areas, or anywhere information might prevent contaminants from being released to stormwater.

Signs and labels should be visible and easy to read. Useful signs and labels might provide the following information:

- Names of facility and regulatory personnel, including emergency phone numbers, to contact in case of an accidental discharge, spill, or other emergency.
- Proper uses of equipment that could cause release of stormwater contaminants.
- Types of chemicals used in high-risk areas.
- The direction of drainage lines/ditches and their destination (treatment or discharge).
- Information on a specific material.
- Refer to OSHA standards for sizes and numbers of signs required for hazardous material labeling.

LIMITATIONS:

No limitations.

MAINTENANCE:

- Periodic checks can ensure that signs are still in place and labels are properly attached.
- Signs and labels should be replaced and repaired as often as necessary.

TARGETED POLLUTANTS

- High Impact
- Medium Impact
- Low or Unknown Impact

- Sediment
- Nutrients
- Heavy Metals
- Toxic Materials
- Oxygen Demanding Substances
- Oil & Grease
- Floatable Materials
- Bacteria & Viruses

IMPLEMENTATION REQUIREMENTS

- Capital Costs
- O&M Costs
- Maintenance
- Training

- High
- Medium
- Low

Materials Adopted From Salt Lake County Engineering Division Guidance Document



DESCRIPTION:

A storm drain is "flushed" with water to suspend and remove deposited materials. Flushing is particularly beneficial for storm drain pipes with grades too flat to be self-cleansing. Flushing helps ensure pipes convey design flow and remove pollutants from the storm drain system.

APPROACH:

- Locate reaches of storm drain with deposit problems and develop a flushing schedule that keeps the pipe clear of excessive buildup.
- Whenever possible, flushed effluent should be collected, decanted, evaporated, and disposed of in a landfill.

LIMITATIONS:

- Most effective in small diameter pipes (36-inch diameter pipe or less, depending on water supply and sediment collection capacity).
- Water source must be available.
- May have difficulty finding downstream area to collect sediments.
- Requires liquid/sediment disposal.

PROGRAM ELEMENTS

- New Development
- Residential
- Commercial Activities
- Industrial Activities
- Municipal Facilities
- Illegal Discharges



TARGETED POLLUTANTS

- High Impact
 - Medium Impact
 - Low or Unknown Impact
- Sediment
 - Nutrients
 - Heavy Metals
 - Toxic Materials
 - Oxygen Demanding Substances
 - Oil & Grease
 - Floatable Materials
 - Bacteria & Viruses

IMPLEMENTATION REQUIREMENTS

- Capital Costs
- O&M Costs
- Regulatory
- Training
- Staffing
- Administrative

- High
- Medium
- Low

Materials Adopted From Salt Lake County Engineering Division Guidance Document



DESCRIPTION:

Sorbents are materials that are capable of cleaning up spills through the chemical processes of adsorption and absorption. Sorbents adsorb (an attraction to the outer surface of a material) or absorb (taken in by the material like a sponge) only when they come in contact with the sorbent materials.

Sorbents include, but are not limited to, the following:

- Common materials such as clays, sawdust, straw and fly ash
- Polymers - polyurethane and polyolefin
- Activated Carbon - powdered or granular
- "Universal Sorbent Material" - a silicate glass foam consisting of rounded particles that can absorb the material.

APPLICATION:

Sorbents are useful BMPs for facilities with liquid materials onsite.

INSTALLATION/APPLICATION CRITERIA:

- Personnel should know the properties of the spilled material(s) to know which sorbent is appropriate. To be effective, sorbents must adsorb the material spilled but must not react with the spilled material to form hazardous or toxic substances.
- Apply immediately to the release area.
- Application is generally simple: the sorbent is added to the area of release, mixed well, and allowed to adsorb or absorb.
- Many sorbents are not reusable once they have been used.
- Proper disposal is required.

LIMITATIONS:

- Requires a knowledge of the chemical makeup of a spill (to choose the best sorbent).
- May be an expensive practice for large spills.
- May create disposal problems and increase disposal costs by creating a solid waste and potentially a hazardous waste.

MAINTENANCE:

No information available.

CONSIDERATIONS

- Soils
- Area Required
- Slope
- Water Availability
- Aesthetics
- Hydraulic Head
- Environmental Side Effects



TARGETED POLLUTANTS

- High Impact
- Medium Impact
- Low or Unknown Impact

- Sediment
- Nutrients
- Heavy Metals
- Toxic Materials
- Oxygen Demanding Substances
- Oil & Grease
- Floatable Materials
- Bacteria & Viruses

IMPLEMENTATION REQUIREMENTS

- Capital Costs
- O&M Costs
- Maintenance
- Training

- High
- Medium
- Low

Materials Adopted From Salt Lake County Engineering Division Guidance Document

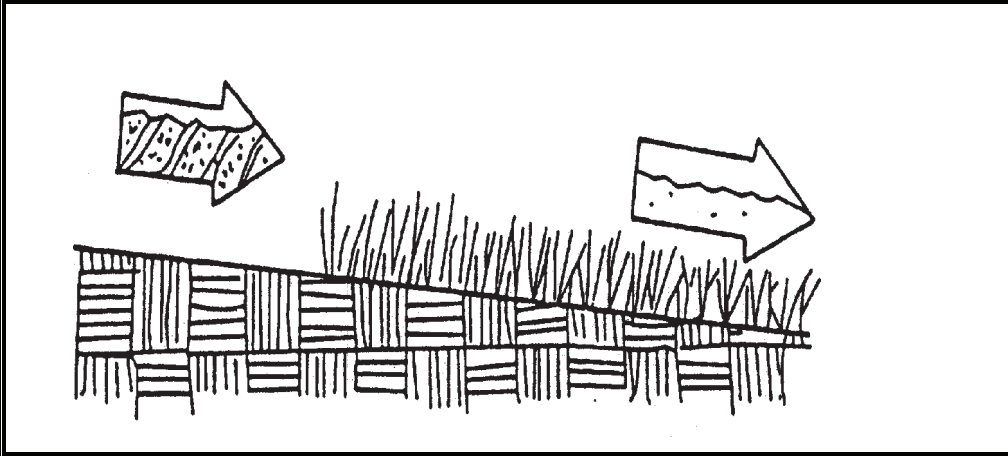

DESCRIPTION:

Seeding of grass and plantings of trees, shrubs, vines and ground covers provide long-term stabilization of soil. In some areas, with suitable climates, grasses can be planted for temporary stabilization.

APPLICATION:

- Appropriate for site stabilization both during construction and post-construction.
- Any graded/cleared areas where construction activities have ceased.
- Open space cut and fill areas.
- Steep slopes, spoil piles, vegetated swales, landscape corridors, stream banks.

INSTALLATION/APPLICATION CRITERIA:

Type of vegetation, site and seedbed preparation, planting time, fertilization and water requirements should be considered for each application.

Grasses:

- Ground preparation: fertilize and mechanically stabilize the soil.
- Tolerant of short-term temperature extremes and waterlogged soil composition.
- Appropriate soil conditions: shallow soil base, good drainage, slope 2:1 or flatter.
- Mowing, irrigating, and fertilizing are vital for promoting vigorous grass growth.

Trees and Shrubs:

- Selection criteria: vigor, species, size, shape & wildlife food source.
- Soil conditions: select species appropriate for soil, drainage & acidity.
- Other factors: wind/exposure, temperature extremes, and irrigation needs.

Vines and Ground Covers:

- Ground preparation: lime and fertilizer preparation.
- Use proper seeding rates.
- Appropriate soil conditions: drainage, acidity and slopes.
- Generally avoid species requiring irrigation.

OBJECTIVES

- Housekeeping Practices
- Contain Waste
- Minimize Disturbed Areas
- Stabilize Disturbed Areas
- Protect Slopes/Channels
- Control Site Perimeter
- Control Internal Erosion



TARGETED POLLUTANTS

- High Impact
- Medium Impact
- Low or Unknown Impact

- Sediment
- Nutrients
- Toxic Materials
- Oil & Grease
- Floatable Materials
- Other Waste

IMPLEMENTATION REQUIREMENTS

- Capital Costs
- O&M Costs
- Maintenance
- Training

- High
- Medium
- Low

MATERIALS ADOPTED FROM SALT LAKE COUNTY ENGINEERING DIVISION GUIDANCE DOCUMENT

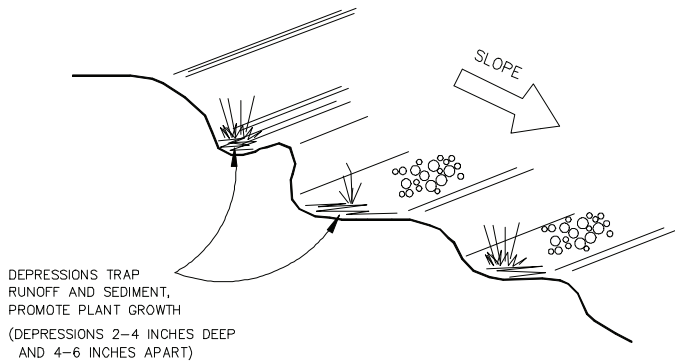

OBJECTIVES

- Housekeeping Practices
- Contain Waste
- Minimize Disturbed Areas
- Stabilize Disturbed Areas
- Protect Slopes/Channels
- Control Site Perimeter
- Control Internal Erosion



DESCRIPTION:

Rough preparation of working areas leaving depressions and uneven surface. Depressions should be done parallel to contours.

APPLICATION:

Surface roughening is appropriate for all construction that will not be receiving impervious cover within 14 days and that will be exposed less than 60 days (seed areas to be open in excess of 60 days).

INSTALLATION/APPLICATION CRITERIA:

- Surface should be left in rough condition during initial earthwork activity.
- Surfaces that have become smoothed or compacted due to equipment traffic should be roughened by use of disks, spring harrows, teeth on front end loader, or similar, operating along the contours of the slope. Tracking (by crawler tractor driving up and down slope) may also be used to provide depressions parallel to contours.
- Avoid compaction of soils during roughening as this inhibits plant growth and promotes storm water runoff. Limit tracked machinery to sandy soil.
- Seed or mulch areas to be exposed in excess of 60 days.
- Employ dust controls. (See Dust Control Detail Sheet).

LIMITATIONS:

- Will not withstand heavy rainfall.
- Slopes steeper than 2:1 (50%) should be benched. (See Benching Detail Sheet).

MAINTENANCE:

- Inspect following any storm event and at a minimum of weekly.
- If erosion in the form of rills (small waterways formed by runoff) is evident, perform machine roughening of area.
- For vegetated slopes reseed areas that are bare or have been reworked.

TARGETED POLLUTANTS

- High Impact
- Medium Impact
- Low or Unknown Impact

- Sediment
- Nutrients
- Toxic Materials
- Oil & Grease
- Floatable Materials
- Other Waste

IMPLEMENTATION REQUIREMENTS

- Capital Costs
- O&M Costs
- Maintenance
- Training

- High
- Medium
- Low

Materials Adopted From Salt Lake County Engineering Division Guidance Document

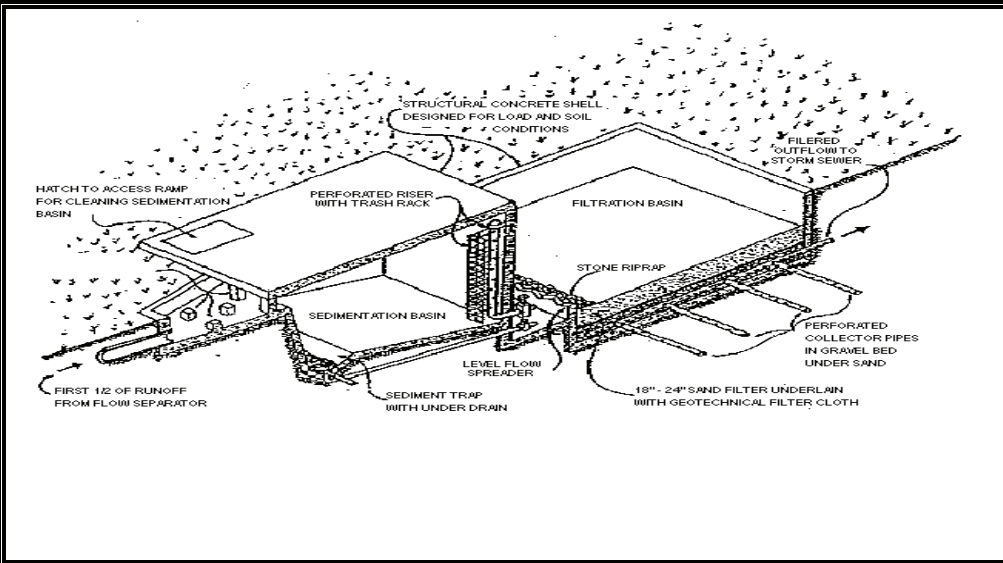

CONSIDERATIONS

- Soils
- Area Required
- Slope
- Water Availability
- Aesthetics
- Hydraulic Head
- Environmental Side Effects

DESCRIPTION:

The surface sand filter system (aka Austin sand filter) consists of a sedimentation chamber or pond followed by a surface sand filter with collector under drains in a gravel bed. Filtered runoff is conveyed to a storm sewer or channel by gravity flow or by pumping.

APPLICATION:

- Commercial and institutional parking lots, small shopping centers, and infill development.
- Smaller redevelopment sites where the use of conventional BMPs is not practical.

INSTALLATION/APPLICATION CRITERIA:

- Filter bed chambers that are too shallow could freeze, causing the filter to become ineffective.
- Pretreatment may be necessary to protect the filter media from excessive sediment loading.
- System should be designed for easy maintenance.

LIMITATIONS:

- Sites with little to no gradient may prevent sufficient gravity flow through the system.
- Extended periods of cold weather could affect pollutant removal efficiency.

MAINTENANCE:

- System should be inspected yearly and after storm events to assess the filtration capacity of the filter.
- Filter sand should be replaced every few years to maintain pollutant removal efficiency.



TARGETED POLLUTANTS

- High Impact
- Medium Impact
- Low or Unknown Impact

- Sediment
- Nutrients
- Heavy Metals
- Toxic Materials
- Oxygen Demanding Substances
- Oil & Grease
- Floatable Materials
- Bacteria & Viruses

IMPLEMENTATION REQUIREMENTS

- Capital Costs
- O&M Costs
- Maintenance
- Training

- High
- Medium
- Low

Materials Adopted From Salt Lake County Engineering Division Guidance Document

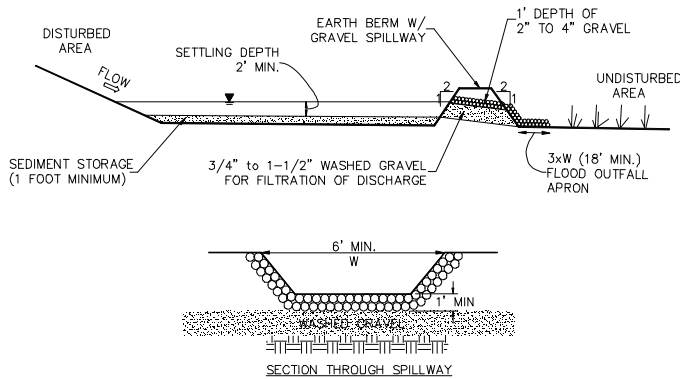

OBJECTIVES

- Housekeeping Practices
- Contain Waste
- Minimize Disturbed Areas
- Stabilize Disturbed Areas
- Protect Slopes/Channels
- Control Site Perimeter
- Control Internal Erosion

DESCRIPTION:

A sediment trap is a small excavated or bermed area where runoff from small drainage areas is detained and sediment can settle.

APPLICATION:

- Temporary control for runoff from disturbed areas of less than 3 acres.
- Temporary control for discharge from diversion dike, surface benching, or other temporary drainage measures.

INSTALLATION/APPLICATION CRITERIA:

- Design basin for site specific location.
- Excavate basin or construct compacted berm containment.
- Construct outfall spillway with apron.
- Provide downstream silt fence if necessary.

LIMITATIONS:

- Should be sized based on anticipated runoff, sediment loading and drainage area size.
- May require silt fence at outlet for entrapment of very fine silts and clays.

MAINTENANCE:

- Inspect after each rainfall event and at a minimum of monthly.
- Repair any damage to berm, spillway or sidewalls.
- Remove accumulated sediment as it reaches 2/3 height of available storage.
- Check outlet for sedimentation/erosion of downgradient area and remediate as necessary. Install silt fence if sedimentation apparent.



TARGETED POLLUTANTS

- High Impact
- Medium Impact
- Low or Unknown Impact

- Sediment
- Nutrients
- Toxic Materials
- Oil & Grease
- Floatable Materials
- Other Waste

IMPLEMENTATION REQUIREMENTS

- Capital Costs
- O&M Costs
- Maintenance
- Training

- High
- Medium
- Low

MATERIALS ADOPTED FROM SALT LAKE COUNTY ENGINEERING DIVISION GUIDANCE DOCUMENT

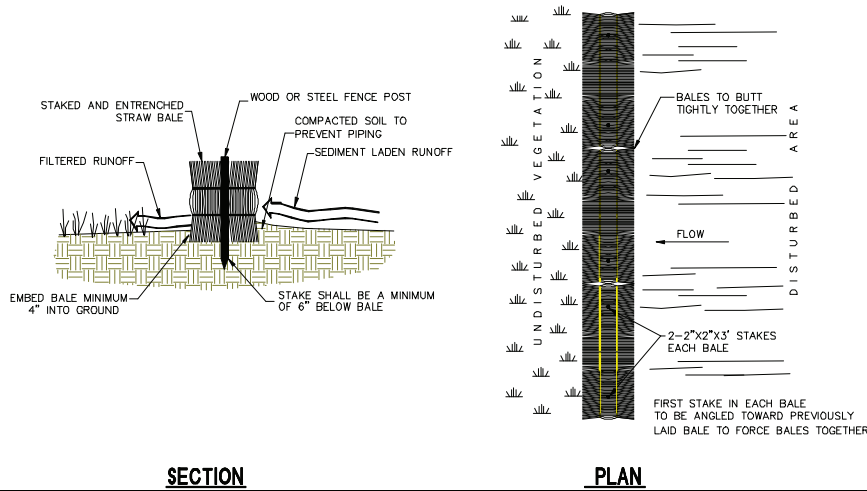

OBJECTIVES

- Housekeeping Practices
- Contain Waste
- Minimize Disturbed Areas
- Stabilize Disturbed Areas
- Protect Slopes/Channels
- Control Site Perimeter
- Control Internal Erosion



DESCRIPTION:

Temporary sediment barrier consisting of a row of entrenched and anchored straw bales.

APPLICATION:

- Perimeter Control: place barrier at downgradient limits of disturbance.
- Sediment barrier: place barrier at toe of slope or soil stockpile.
- Protection of existing waterways: place barrier at top of stream bank.
- Inlet Protection.

INSTALLATION/APPLICATION CRITERIA:

- Excavate a 4-inch minimum deep trench along contour line, i.e. parallel to slope, removing all grass and other material that may allow underflow.
- Place bales in trench with ends tightly abutting, fill any gaps by wedging loose straw into openings.
- Anchor each bale with 2 stakes driven flush with the top of the bale.
- Backfill around bale and compact to prevent piping, backfill on uphill side to be built up 4-inches above ground at the barrier.

LIMITATIONS:

- Recommended maximum area of 0.5 acre per 100 feet of barrier
- Recommended maximum upgradient slope length of 150 feet
- Recommended maximum uphill grade of 2:1 (50%)

MAINTENANCE:

- Inspect immediately after any rainfall and at least daily during prolonged rainfall.
- Look for runoff bypassing ends of barriers or undercutting barriers.
- Repair or replace damaged areas of the barrier and remove accumulated sediment.
- Realign bales as necessary to provide continuous barrier and fill gaps.
- Recompect soil around barrier as necessary to prevent piping.

TARGETED POLLUTANTS

- High Impact
- Medium Impact
- Low or Unknown Impact

- Sediment
- Nutrients
- Toxic Materials
- Oil & Grease
- Floatable Materials
- Other Waste

IMPLEMENTATION REQUIREMENTS

- Capital Costs
- O&M Costs
- Maintenance
- Training

- High
- Medium
- Low

Materials Adopted From Salt Lake County Engineering Division Guidance Document

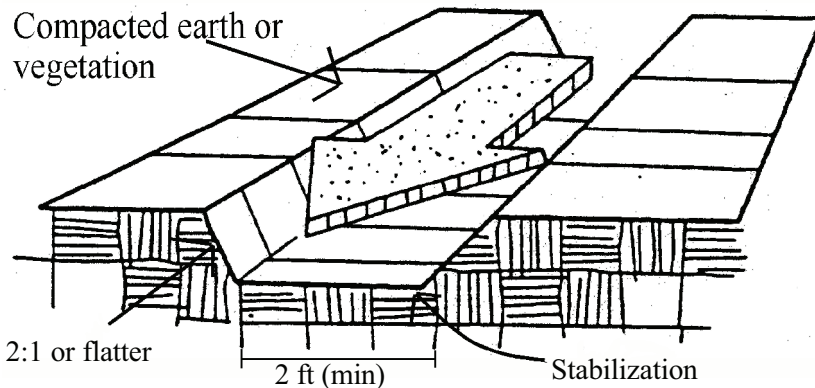

OBJECTIVES

- Housekeeping Practices
- Contain Waste
- Minimize Disturbed Areas
- Stabilize Disturbed Areas
- Protect Slopes/Channels
- Control Site Perimeter
- Control Internal Erosion

DESCRIPTION:

Temporary drains and swales are used to divert off-site runoff around the construction site, divert runoff from stabilized areas around disturbed areas, and direct runoff into sediment.

APPLICATIONS:

- Temporary drains and swales are appropriate for diverting any upslope runoff around unstabilized or disturbed areas of the construction site.
- Prevent slope failures. Prevent damage to adjacent property. Prevents erosion and transport of sediments into water ways. Increases the potential for infiltration. Diverts sediment-laden runoff into sediment basins or traps.

INSTALLATION/APPLICATION:

- Temporary drainage swales will effectively convey runoff and avoid erosion if built properly:
- Size temporary drainage swales using local drainage design criteria. A permanent drainage channel must be designed by a professional engineer (see the local drainage design criteria for proper design).
- At a minimum, the drain/swale should conform to predevelopment drainage patterns and capacities.
- Construct the drain/swale with an uninterrupted, positive grade to a stabilized outlet. Provide erosion protection or energy dissipation measures if the flow out of the drain or swale can reach an erosive velocity.

LIMITATIONS:

- Temporary drains and swales or any other diversion of runoff should not adversely impact upstream or downstream properties.
- Temporary drains and swales must conform to local floodplain management requirements.

MAINTENANCE:

- Inspect weekly and after each rain.
- Repair any erosion immediately.
- Remove sediment which builds up in the swale and restricts its flow capacity.



TARGETED POLLUTANTS

- High Impact
- Medium Impact
- Low or Unknown Impact

- Sediment
- Nutrients
- Toxic Materials
- Oil & Grease
- Floatable Materials
- Other Waste

IMPLEMENTATION REQUIREMENTS

- Capital Costs
- O&M Costs
- Maintenance
- Training

- High
- Medium
- Low

Materials Adopted From Salt Lake County Engineering Division Guidance Document



OBJECTIVES

- Housekeeping Practices
- Contain Waste
- Minimize Disturbed Areas
- Stabilize Disturbed Areas
- Protect Slopes/Channels
- Control Site Perimeter
- Control Internal Erosion



DEFINITION:

Temporary seeding - establishment of short term cover by application of rapidly germinating seed mix (alternatively hydroseeding may be utilized).
Permanent seeding - establishment of final term cover by application of perennial seed mix (alternatively sod may be utilized).

APPLICATION:

Disturbed areas that are at final grade and which will not be disturbed by continuing activities on site. Also areas that are not at final grade but which will be left untouched in excess of one year.

RECOMMENDED SEED MIX:

The recommended seed mix will be dependent on site specific information such as elevation, exposure, soils, water available and topography. Check with the County Extension Service for recommended mixes for site specific conditions:

Utah State University Extension Service
 2001 South State Street #S1200
 Salt Lake City, Utah 84190
 phone (801) 468-3170

LIMITATIONS:

- Limited to areas that will not be subject to traffic or high usage.
- May require irrigation and fertilizer which creates potential for impacting runoff quality.
- May only be applied during appropriate planting season, temporary cover required until that time.

INSTALLATION:

- Roughen soil to a depth of 2 inches. Add fertilizer, manure, topsoil as necessary.
- Evenly distribute seed using a commonly accepted method such as; breast seeding, drilling, hydroseeding.
- Use a seed mix appropriate for soil and location that will provide rapid germination and growth. Check with County for recommended mix and application rate.
- Cover area with mulch if required due to steep slopes or unsuitable weather conditions.

MAINTENANCE:

- Provide irrigation as required to establish growth and to maintain plant cover through duration of project.
- Reseed as necessary to provide 75% coverage
- Remediate any areas damaged by erosion or traffic.
- When 75% coverage is achieved inspect monthly for damage and remediate as necessary.

TARGETED POLLUTANTS

- High Impact
- Medium Impact
- Low or Unknown Impact

- Sediment
- Nutrients
- Toxic Materials
- Oil & Grease
- Floatable Materials
- Other Waste

IMPLEMENTATION REQUIREMENTS

- Capital Costs
- O&M Costs
- Maintenance
- Training

- High
- Medium
- Low

MATERIALS ADOPTED FROM SALT LAKE COUNTY ENGINEERING DIVISION GUIDANCE DOCUMENT

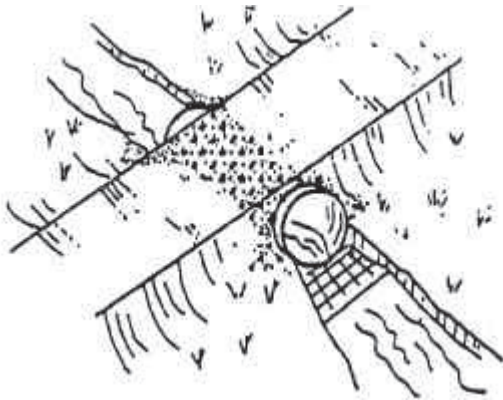

OBJECTIVES

- Housekeeping Practices
- Contain Waste
- Minimize Disturbed Areas
- Stabilize Disturbed Areas
- Protect Slopes/Channels
- Control Site Perimeter
- Control Internal Erosion



DESCRIPTION:

A temporary access stream crossing is a temporary culvert, ford or bridge placed across a waterway to provide access for construction purposes for a period of less than one year. Temporary access crossings are not intended to be used to maintain traffic for the general public.

APPLICATIONS:

Temporary stream crossings should be installed at all designated crossings of perennial and intermittent streams on the construction site, as well as for dry channels which may be significantly eroded by construction traffic.

INSTALLATION/APPLICATION:

Requires knowledge of stream flows and soil strength and should be designed under the direction of a Utah registered engineer with knowledge of both hydraulics and construction loading requirements for structures.

LIMITATIONS:

- May be an expensive for a temporary improvement.
- Requires other BMP's to minimize soil disturbance during installation and removal.
- Fords should only be used in dry weather.
- A Stream Alteration Permit may be required, contact the Utah Division of Water Rights before implementation.

MAINTENANCE:

- Inspect weekly and after each significant rainfall, including assessment of foundations.
- Periodically remove silt from crossings.
- Replace lost aggregated from inlets and outlets of culverts.

TARGETED POLLUTANTS

- High Impact
- Medium Impact
- Low or Unknown Impact

- Sediment
- Nutrients
- Toxic Materials
- Oil & Grease
- Floatable Materials
- Other Waste

IMPLEMENTATION REQUIREMENTS

- Capital Costs
- O&M Costs
- Maintenance
- Training

- High
- Medium
- Low

Materials Adopted From Salt Lake County Engineering Division Guidance Document

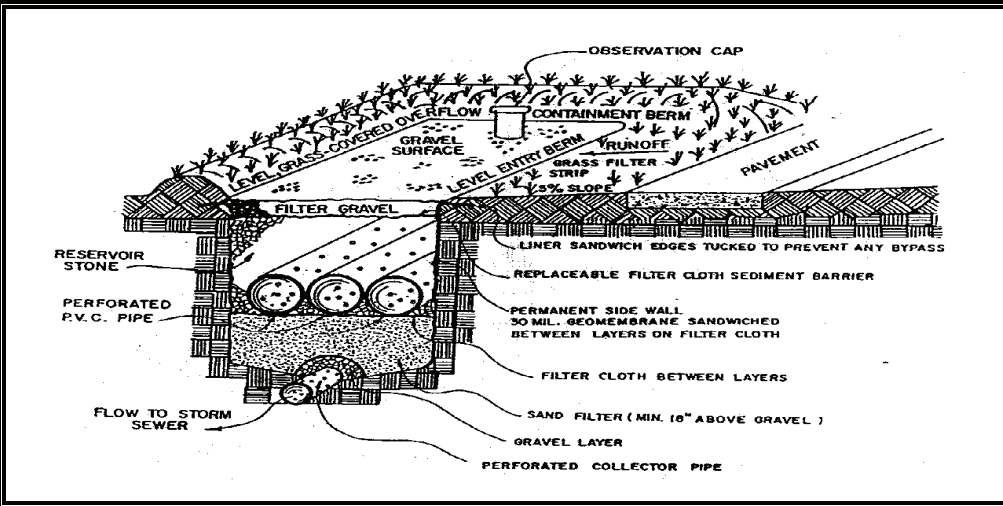

CONSIDERATIONS

- Soils
- Area Required
- Slope
- Water Availability
- Aesthetics
- Hydraulic Head
- Environmental Side Effects



DESCRIPTION:

An adaptation of the surface sand filter system. The trench sand filter system has two variations. One variation consists of a trench sand filter system with a stone reservoir. The other variation consists of a trench sand filter system with a small sedimentation pond.

APPLICATION:

Townhouse developments or small commercial redevelopments.

INSTALLATION/APPLICATION CRITERIA:

- Topography should offer sufficient relief to allow the system to function by gravity flow.
- Design for easy maintenance accessibility.
- Design for safety barriers which prevent children from entering the sedimentation pond.

LIMITATIONS:

- Sites with little or no gradient may prevent sufficient gravity flow through the systems.
- Not recommended for parking lots.

MAINTENANCE:

- Stone reservoirs will require periodic replacement of the upper filter cloth and gravel layer.
- Sedimentation ponds will require periodic removal of accumulated sediment.

TARGETED POLLUTANTS

- High Impact
- Medium Impact
- Low or Unknown Impact

- Sediment
- Nutrients
- Heavy Metals
- Toxic Materials
- Oxygen Demanding Substances
- Oil & Grease
- Floatable Materials
- Bacteria & Viruses

IMPLEMENTATION REQUIREMENTS

- Capital Costs
- O&M Costs
- Maintenance
- Training

- High
- Medium
- Low

Materials Adopted From Salt Lake County Engineering Division Guidance Document

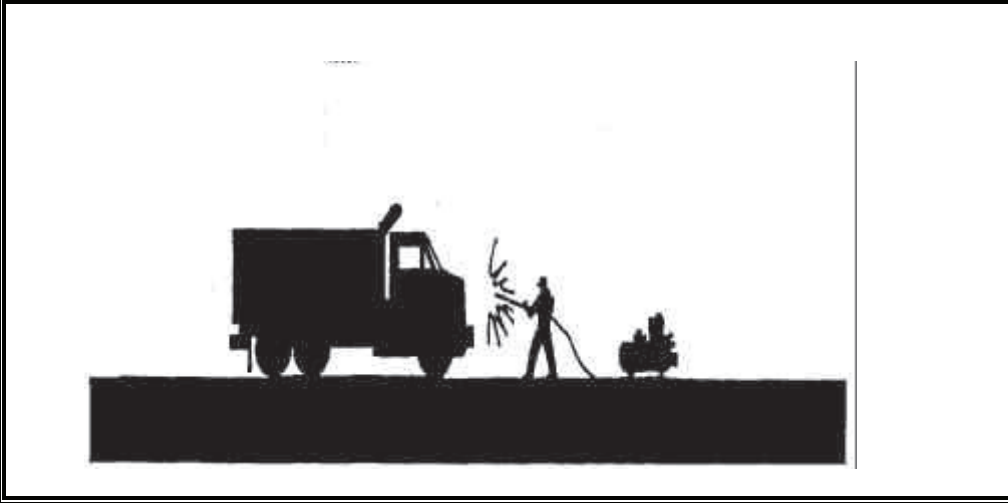

OBJECTIVES

- Housekeeping Practices
- Contain Waste
- Minimize Disturbed Areas
- Stabilize Disturbed Areas
- Protect Slopes/Channels
- Control Site Perimeter
- Control Internal Erosion



DESCRIPTION:

Prevent or reduce the discharge of pollutants to storm water from vehicle and equipment cleaning by using off-site facilities, washing in designated, contained areas only, eliminating discharges to the storm drain by infiltrating or recycling the wash water, and/or training employees and subcontractors.

INSTALLATION/APPLICATION:

- Use off-site commercial washing businesses as much as possible. Washing vehicles and equipment outdoors or in areas where wash water flows onto paved surfaces or into drainage pathways can pollute storm water. If you wash a large number of vehicles or pieces of equipment, consider conducting this work at an off-site commercial business. These businesses are better equipped to handle and dispose of the wash waters properly. Performing this work off-site can also be economical by eliminating the need for a separate washing operation at your site.
- If washing must occur on-site, use designated, bermed wash areas to prevent wash water contact with storm water, creeks, rivers, and other water bodies. The wash area can be sloped for wash water collection and subsequent infiltration into the ground.
- Use as little water as possible to avoid having to install erosion and sediment controls for the wash area. Use phosphate-free biodegradable soaps. Educate employees and subcontractors on pollution prevention measures. Do not permit steam cleaning on-site. Steam cleaning can generate significant pollutant concentrations.

LIMITATIONS:

- Even phosphate-free, biodegradable soaps have been shown to be toxic to fish before the soap degrades.
- Sending vehicles/equipment off-site should be done in conjunction with Stabilized Construction Entrance.

MAINTENANCE:

- Minimal, some berm repair may be necessary.

TARGETED POLLUTANTS

- High Impact
- Medium Impact
- Low or Unknown Impact

- Sediment
- Nutrients
- Toxic Materials
- Oil & Grease
- Floatable Materials
- Other Waste

IMPLEMENTATION REQUIREMENTS

- Capital Costs
- O&M Costs
- Maintenance
- Training

- High
- Medium
- Low

Materials Adopted From Salt Lake County Engineering Division Guidance Document

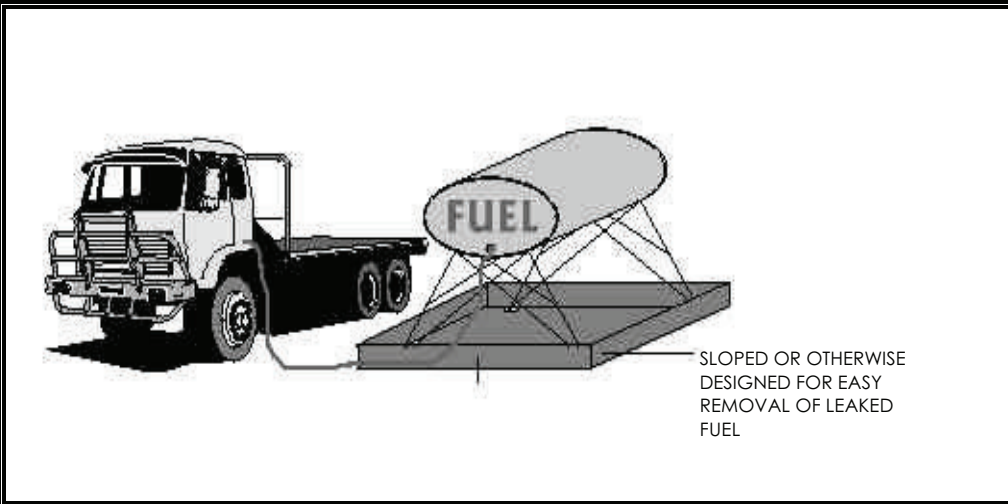

DESCRIPTION:

Prevent fuel spills and leaks, and reduce their impacts to storm water by using off-site facilities, fueling in designated areas only, enclosing or covering stored fuel, implementing spill controls, and training employees and subcontractors.

INSTALLATION/APPLICATION:

- Use off-site fueling stations as much as possible. Fueling vehicles and equipment outdoors or in areas where fuel may spill/leak onto paved surfaces or into drainage pathways can pollute storm water. If you fuel a large number of vehicles or pieces of equipment, consider using an off-site fueling station. These businesses are better equipped to handle fuel and spills properly. Performing this work off-site can also be economical by eliminating the need for a separate fueling area at your site.
- If fueling must occur on-site, use designated areas, located away from drainage courses, to prevent the runoff of storm water and the runoff of spills. Discourage "topping-off" of fuel tanks.
- Always use secondary containment, such as a drain pan or drop cloth, when fueling to catch spills/leaks. Place a stockpile of spill cleanup materials where it will be readily accessible. Use adsorbent materials on small spills rather than hosing down or burying the spill. Remove the adsorbent materials promptly and dispose of properly.
- Carry out all Federal and State requirements regarding stationary above ground storage tanks.(40 CF Sub. J) Avoid mobile fueling of mobile construction equipment around the site; rather, transport the equipment to designated fueling areas. With the exception of tracked equipment such as bulldozers and perhaps forklifts, most vehicles should be able to travel to a designated area with little lost time. Train employees and subcontractors in proper fueling and cleanup procedures.

LIMITATIONS:

Sending vehicles/equipment off-site should be done in conjunction with Stabilized Construction Entrance.

MAINTENANCE:

- Keep ample supplies of spill cleanup materials on-site.
- Inspect fueling areas and storage tanks on a regular schedule.

OBJECTIVES

- Housekeeping Practices
- Contain Waste
- Minimize Disturbed Areas
- Stabilize Disturbed Areas
- Protect Slopes/Channels
- Control Site Perimeter
- Control Internal Erosion



TARGETED POLLUTANTS

- High Impact
- Medium Impact
- Low or Unknown Impact

- Sediment
- Nutrients
- Toxic Materials
- Oil & Grease
- Floatable Materials
- Other Waste

IMPLEMENTATION REQUIREMENTS

- Capital Costs
- O&M Costs
- Maintenance
- Training

- High
- Medium
- Low

Materials Adopted From Salt Lake County Engineering Division Guidance Document

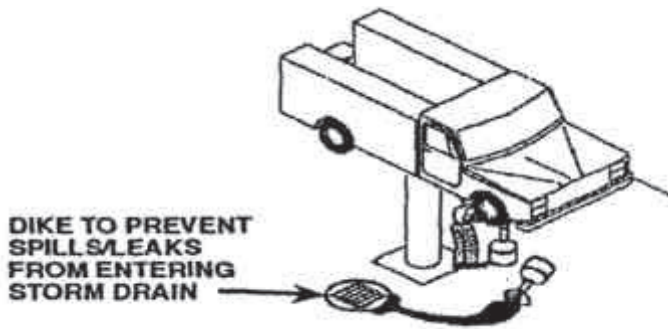

(INSIDE MAINTENANCE FACILITY)

DESCRIPTION:

Prevent or reduce the discharge of pollutants to stormwater from vehicles and equipment maintenance and repair by running a dry shop.

APPROACH:

- Keep equipment clean, don't allow excessive build-up of oil and grease.
- Keep drip pans or containers under the areas that might drip.
- Do not change motor oil or perform equipment maintenance in non-appropriate areas.
- Inspect equipment for leaks on a regular basis.
- Segregate wastes.
- Make sure oil filters are completely drained and crushed before recycling or disposal.
- Make sure incoming vehicles are checked for leaking oil and fluids.
- Clean yard storm drain inlets regularly and especially after large storms.
- Do not pour materials down drains or hose down work areas; use dry seeping.
- Store idle equipment under cover.
- Drain all fluids from wrecked vehicles.
- Recycle greases, used oil or oil filters, antifreeze, cleaning solutions, automotive batteries, hydraulic, and transmission fluids.
- Switch to non-toxic chemicals for maintenance when possible.
- Clean small spills with rags, general clean-up with damp mops and larger spills with absorbent material.
- Paint signs on storm drain inlets to indicate that they are not to receive liquid or solid wastes.
- Train employees, minimize use of solvents.

LIMITATIONS:

- Space and time limitations may preclude all work being conducted indoors.
- It may not be possible to contain and clean up spills from vehicles/equipment brought on-site after working hours.
- Dry pans are generally too small to contain antifreeze, which may gush from some vehicles, so drip pans may have to be purchased or fabricated.
- Dry floor cleaning methods may not be sufficient for some spills.

MAINTENANCE:

Should be low if procedures for the approach are followed.

APPLICATIONS

- Manufacturing
- Material Handling
- Vehicle Maintenance
- Construction
- Commercial Activities
- Roadways
- Waste Containment
- Housekeeping Practices



TARGETED POLLUTANTS

- High Impact
- Medium Impact
- Low or Unknown Impact

- Sediment
- Nutrients
- Heavy Metals
- Toxic Materials
- Oxygen Demanding Substances
- Oil & Grease
- Floatable Materials
- Bacteria & Viruses

IMPLEMENTATION REQUIREMENTS

- Capital Costs
- O&M Costs
- Maintenance
- Training

- High
- Medium
- Low

Materials Adopted From Salt Lake County Engineering Division Guidance Document

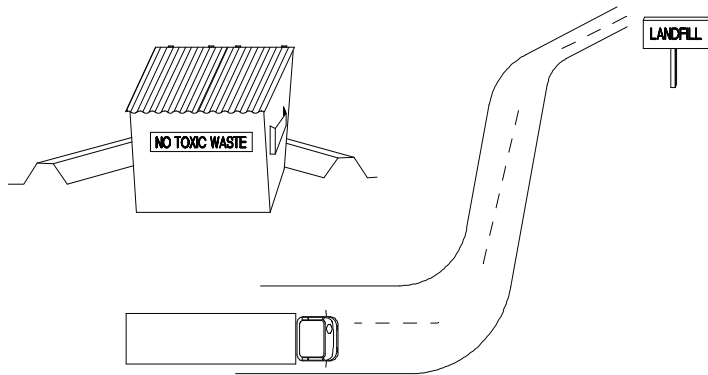

OBJECTIVES

- Housekeeping Practices
- Contain Waste
- Minimize Disturbed Areas
- Stabilize Disturbed Areas
- Protect Slopes/Channels
- Control Site Perimeter
- Control Internal Erosion



DESCRIPTION:

Controlled storage and disposal of solid waste generated by construction activities.

APPLICATION:

All construction sites.

INSTALLATION:

- Designate one or several waste collection areas with easy access for construction vehicles and personnel. Ensure no waterways or storm drainage inlets are located near the waste collection areas.
- Construct compacted earthen berm (See Earth Berm Barrier Information Sheet), or similar perimeter containment around collection area for impoundment in the case of spills and to trap any windblown trash.
- Use water tight containers with covers to remain closed when not in use. Provide separate containers for different waste types where appropriate and label clearly.
- Ensure all on site personnel are aware of and utilize designated waste collection area properly and for intended use only (e.g. all toxic, hazardous, or recyclable materials shall be properly disposed of separately from general construction waste).
- Arrange for periodic pickup, transfer and disposal of collected waste at an authorized disposal location. Include regular Porto-potty service in waste management activities.

LIMITATIONS:

- On-site personnel are responsible for correct disposal of waste.

MAINTENANCE:

- Discuss waste management procedures at progress meetings.
- Collect site trash daily and deposit in covered containers at designated collection areas.
- Check containers for leakage or inadequate covers and replace as needed.
- Randomly check disposed materials for any unauthorized waste (e.g. toxic materials).
- During daily site inspections check that waste is not being incorrectly disposed of on-site (e.g. burial, burning, surface discharge, discharge to storm drain).

TARGETED POLLUTANTS

- High Impact
- Medium Impact
- Low or Unknown Impact

- Sediment
- Nutrients
- Toxic Materials
- Oil & Grease
- Floatable Materials
- Other Waste

IMPLEMENTATION REQUIREMENTS

- Capital Costs
- O&M Costs
- Maintenance
- Training

- High
- Medium
- Low

Materials Adopted From Salt Lake County Engineering Division Guidance Document

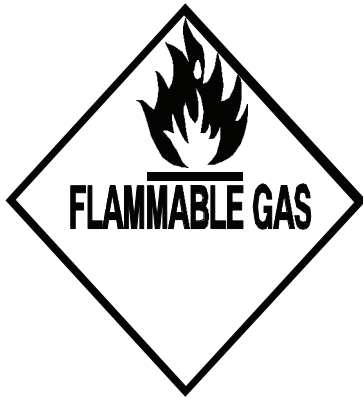

APPLICATIONS

- Manufacturing
- Material Handling
- Vehicle Maintenance
- Construction
- Commercial Activities
- Roadways
- Waste Containment
- Housekeeping Practices

DESCRIPTION:

Prevent or reduce the discharge of pollutants to stormwater from waste handling and disposal by tracking waste generation, storage, and disposal; reducing waste generation and disposal through source reduction, re-use, and recycling; and preventing runoff and runoff from waste management areas.

APPROACH:

- Maintain usage inventory to limit waste generation.
- Substitute or eliminate raw materials.
- Modify process or equipment.
- SARA Title III, Section 313 requires reporting for over 300 listed chemicals and chemical compounds. This requirement should be used to track these chemicals although this is not as accurate a means of tracking as other approaches.
- Track waste generated.
- Use design data and review: process flow diagram, materials and applications diagram, piping and instructions, equipment list, plot plan.
- Use economic data and review: Waste treatment and disposal cost. Product utility and economic cost. Operation and maintenance labor cost.
- Recycle materials whenever possible.
- Maintain list of and the amounts of materials disposed.
- Segregation and separate waste.
- Cover, enclose, or berm industrial wastewater management areas whenever possible to prevent contact with runoff or runoff.
- Equip waste transport vehicles with anti-spill equipment.
- Minimize spills and fugitive losses such as dust or mist from loading systems.
- Ensure that sediments or wastes are prevented from being tracked off-site.
- Training and supervision.
- Stencil storm drains on the facility's property with prohibitive message regarding waste disposal.

LIMITATIONS:

Hazardous waste that cannot be re-used or recycled must be disposed of by a licensed hazardous waste hauler.



TARGETED POLLUTANTS

- High Impact
- Medium Impact
- Low or Unknown Impact

- Sediment
- Nutrients
- Heavy Metals
- Toxic Materials
- Oxygen Demanding Substances
- Oil & Grease
- Floatable Materials
- Bacteria & Viruses

IMPLEMENTATION REQUIREMENTS

- Capital Costs
- O&M Costs
- Maintenance
- Training

- High
- Medium
- Low

Materials Adopted From Salt Lake County Engineering Division Guidance Document

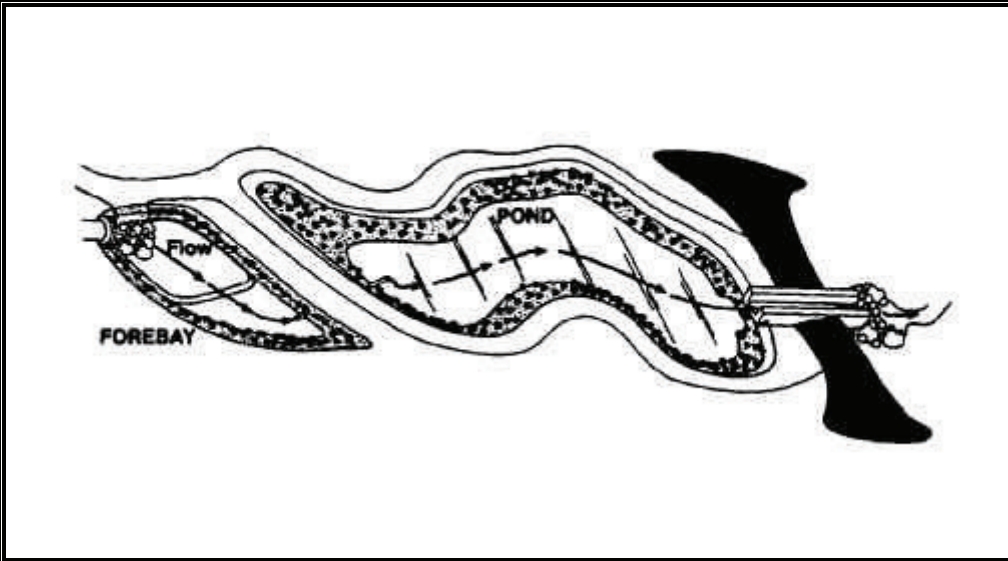

DESCRIPTION:

A wet pond has a permanent water pool to treat incoming stormwater. An enhanced wet pond includes a pretreatment sediment forebay.

APPLICATION:

- Need to achieve high level of particulate and some dissolved contaminant removal.
- Ideal for large, regional tributary areas.
- Multiple benefits of passive recreation (e.g. bird watching, wildlife habitat).

INSTALLATION/APPLICATION CRITERIA:

- Water depth of 3 to 9 feet.
- Wetland vegetation, occupying 25-50% of water surface area.
- Design to minimize short-circuiting.
- Bypass storms greater than two year storm.
- Be careful when installing wetland vegetation.

LIMITATIONS:

- Concern for mosquitoes and maintaining oxygen in ponds.
- Cannot be placed on steep unstable slopes.
- Need base flow or supplemental water if water level is to be maintained.
- Infeasible in very dense urban areas.

MAINTENANCE:

- Remove floatables and sediment build-up.
- Correct erosion spots in banks.
- Control mosquitoes.
- May require permits from various regulatory agencies, e.g. Corps of Engineers.

CONSIDERATIONS

- Soils
- Area Required
- Slope
- Water Availability
- Aesthetics
- Hydraulic Head
- Environmental Side Effects



TARGETED POLLUTANTS

- High Impact
- Medium Impact
- Low or Unknown Impact

- Sediment
- Nutrients
- Heavy Metals
- Toxic Materials
- Oxygen Demanding Substances
- Oil & Grease
- Floatable Materials
- Bacteria & Viruses

IMPLEMENTATION REQUIREMENTS

- Capital Costs
- O&M Costs
- Maintenance
- Training

- High
- Medium
- Low

Materials Adopted From Salt Lake County Engineering Division Guidance Document